

eclair A.C.L. CAMERA  OPERATING MANUAL



1st PART-

When using your ECLAIR ACL you will realize that our aim :

TO REDUCE TO THE MINIMUM THE WEIGHT AND SIZE OF A 100 % PROFESSIONAL CAMERA WHILST RETAINING A VERY LOW NOISE LEVEL

has been entirely achieved.

The characteristics which have given ECLAIR cameras their world wide reputation have been retained :

- snap-on magazines
- high efficiency reflex viewfinder with a field of view greater than the image
- mounts for many lenses (C- CA Eclair- Arriflex- Nikon- etc.)

- silent mechanism ensuring a very low noise level without the need of any blimp
- crystal-controlled brushless motor
- definition and steadiness to the highest professional standards
- exceptional portability.

Using an ACL is very simple. Nevertheless, we suggest that by following the instructions in this manual you will be certain to obtain the optimum results you are entitled to expect from an equipment which has been conceived to give you full satisfaction.

N° 7615

SUMMARY OF CONTENTS

1st part GENERALITIES		2nd part INSTRUCTIONS	
	Pages		Pages
INTRODUCTION	1	MOUNTING OF THE LENS	17
SUMMARY : 1st and 2nd parts	2	DIOPTRY ADJUSTEMENT	18
TECHNICAL CHARACTERISTICS	3	GELATINE HOLDER	19
DESCRIPTION		HAND-GRIP	19
Camera head (codes MIPEX and MITAN)	4	150 E ELECTRONIC BASE FUNCTIONS	20
Multiduty motor (MIVAR)	5	FILM LOADING :	
60 meter magazine (MICHA)	6	· in 60 m magazine, on 50 mm core	21
120 meter magazine (MIVIN)	6	(indications on the footage counter)	
Hand-grip	7	· in 60 m magazine, on daylight spool	22
Lens mount	7	(indications on the audible warning loop resorb system)	
ACCESSORIES	8	Loading of a 120 m magazine	22
GENERAL INFORMATION :		Feed side. Take-up side. Footage counter	22
Reflex sight	9	Mounting the magazine on the camera .. To remove the magazine	23
Gelatine holder	9	STARTING THE CAMERA	24
Shutter	9	Warning system in the magazine	25
Mechanism	10	EXPOSURE INDICATOR	25
Exposure indicator	10	Characteristics, advantages of the system, light compensation	
Electronic base 150 E	11	(setting), filming	
PILOTONE MODULE	11	FOOTAGE INDICATOR	25
BATTERY (MIBAC)	12	(MIBAC) BATTERY AND ITS RAPID-CHARGER	27
BATTERY CHARGER FOR MIBAC	12	(BAKEL) BATTERY AND ITS COMPACT CHARGER	28
BATTERY (BAKEL)	13	ACCESSORIES :	
BATTERY CHARGER FOR BAKEL (CIBRE)	13	Pilotone-module .. Filter holder wallet .. Transport case	29
TRANSPORT CASE	13	MAINTENANCE RECOMMANDATIONS	29
CABLES AND PLUGS	14	CHANGING THE MOTOR	30
CONNECTIONS	15	FILMING IN EXCESSIVE TEMPERATURES	31
		AFTER-SALES	32
		USEFUL INFORMATION : weights and dimensions	33
		ACL EXPOSURE-TIME TABLE	33
		FIGURES AND DIAGRAMS REFERENCES	34

TECHNICAL CHARACTERISTICS

Weight :

4,3 kg without lens.

Overall dimensions :

275x180x160 mm, without lens (11"x7"x6" 1/2)

Capacity :

pre-loaded 60 meter (200 ft) or 120 m (400 ft)
snap-on magazine

16 mm film :

- double or single perforation
- A winding (emulsion out)
- B winding (emulsion in)
- on 50 mm (2in) core-120 meter rolls
- on 30 or 60 m (100 or 200 ft) daylight loading spools

Climatic conditions :

Temperature — 20 °C (4 °F) to + 60 °C (140 °F)
Humidity : up to 95 % RH

Film transport :

claw movement controlled by an excentric
and a fixed cam.

Reflex viewing :

by a half-speed oscillating mirror.

Shutter :

plane type with 175° opening.

Viewfinder :

for left and/or right eye, rotatable through
360° with image re-erected, dioptre adjustment
and eyepiece shutter.

Gelatine holder :

built-in and positioned between the C mount
and the reflex mirror.

Lens mounts :

in C mount, screwed directly on to the camera,
in Cameflex, Arriflex or Nikon mounts,
adapted to the camera by means of intermediate
mount.

Exposure indicator :

by 7 LED (light emitting diodes) in vertical
display seen in viewfinder.

Motor :

12 volts multiduty type, brushless, Hall effect,
6 crystal controlled speeds 8, 12, 24, 25,
50, 75 frames per second. Automatic stop
in viewing position.

Power consumption :

from 0,8 to 1,2 Amps at 12 volts (20 °C or 68 °F).

Batteries :

12 volts MIBAC type : weight 0,640 gr (1,5 lbs)
(capacity 1,2 ah) ; rechargeable in less than
30 minutes equivalent to eight to ten 60 m
magazines or 12 volts BAKEL type :
weight 1,650 kg, capacity 4 ah equivalent
to ten to fifteen magazines

Noise level :

Quiet functioning that permits sync. filming
without any blimp.

Flat base :

standard 3/8"x16 threads per inch tapping
for using a tripod or a polo stick.

Hand-grip :

adjustable lateral type with "ON/OFF"
micro-switch.

Standard screw :

on top of the camera for attachment
of accessories such as handle, boost lighting,
mike support, etc.



DESCRIPTION

THE CAMERA HEAD (Code MIPEX)

The camera head (Fig A) in special aluminium alloy supports the lens mounts (1) in stainless steel, the interchangeable gelatine-holder (2), the reflex viewfinder (3), the motor (6) with its control for electronics (7), the electronic base (8) incorporating the sliding on/off switch (32), the lateral support (75) of the hand-grip (36) with its micro-switch (76), the magazine lock release lever (16) with its safety catch (17) and the removable hand-grip (36).

On the rear (Fig B) : the mechanism plate (9) on which are mounted the film gate (10),

the fixed guide bar (11) and its side pressure bar (12), the magazine drive shaft (18), the 4 pin power supply socket (19) for connection with the battery, the clapper switch (20) and the potentiometer (34) of the exposure indicator.

Inside : the claw mechanism (13), the oscillating mirror (14), the plane shutter (15) and the exposure indicator unit.

The snap-on 60 m, or 120 m magazine are attached onto the camera head as well as the fixed focal or zoom lenses.

NOTA. The above camera head can be supplied without Exposure indicator unit; its commercial code is MITAN.

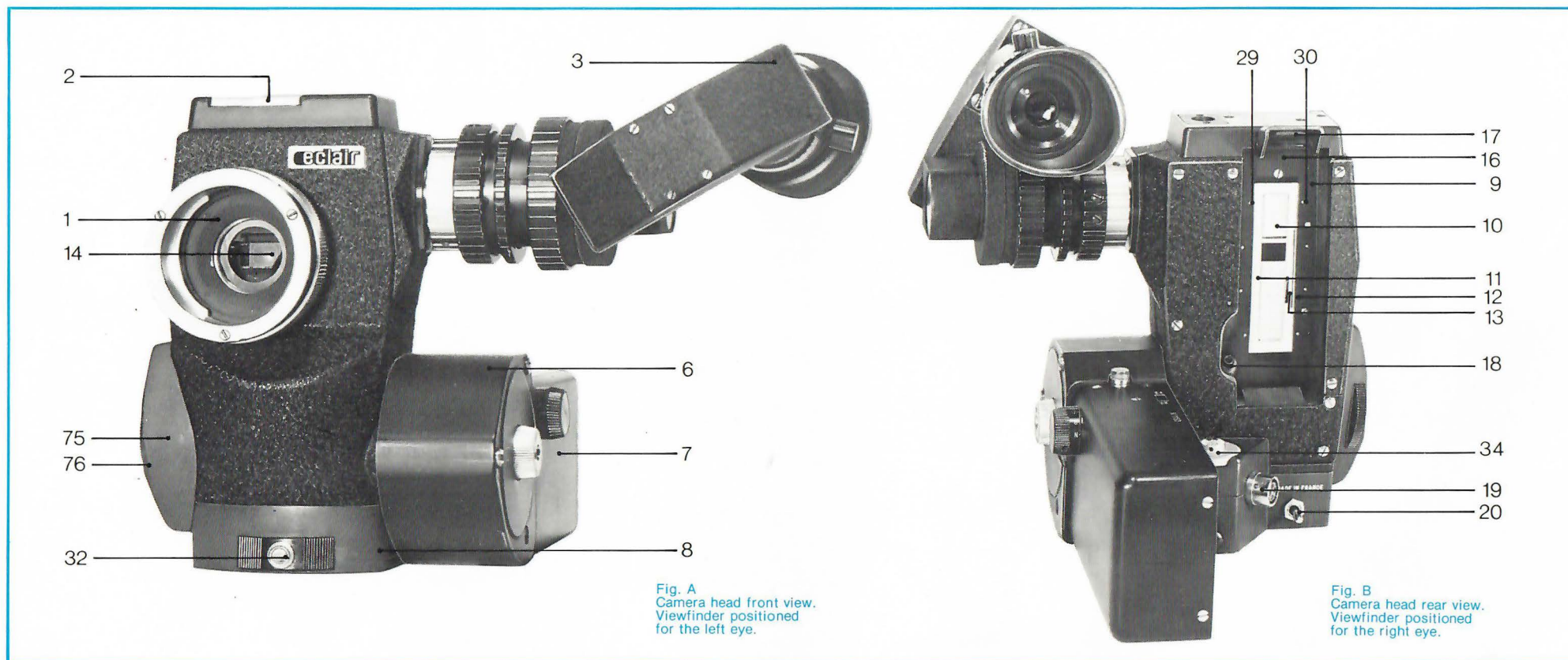

Fig. A
Camera head front view.
Viewfinder positioned
for the left eye.

Fig. B
Camera head rear view.
Viewfinder positioned
for the right eye.



THE MULTIDUTY MOTOR (MIVAR)

This brushless motor (6) has a very high efficiency (from 0.8 to 1.2 amp. consumption at 12 volts to drive the camera at 20°C (68°F) and has permitted a weight reduction not only in the camera but also in the battery (37) — page 12 — which weighs only 640 grammes enabling one hour of filming between recharges, i.e. eight to ten 60 m magazines.

The incorporated electronics (7) control the sync. speed by crystal; changing from 24 to 25 f.p.s. or vice-versa is made by shifting switch (38) so that the white spot mark is adjacent to the desired speed. Others speeds : 8.12.50 and 75 are obtained by setting the engraved button 35 accordingly.

The MIVAR will stop the camera automatically in viewing position, i.e. the mirror being in the aperture axis allows the cameraman to frame and focus without loss of time. See pages 24 and 30.

The motor will only operate when it is attached to the camera.

The lamp (47) on the motor lights up until the marked speed is attained. In the event of speed reduction (flat battery for example) the warning lamp lights up.

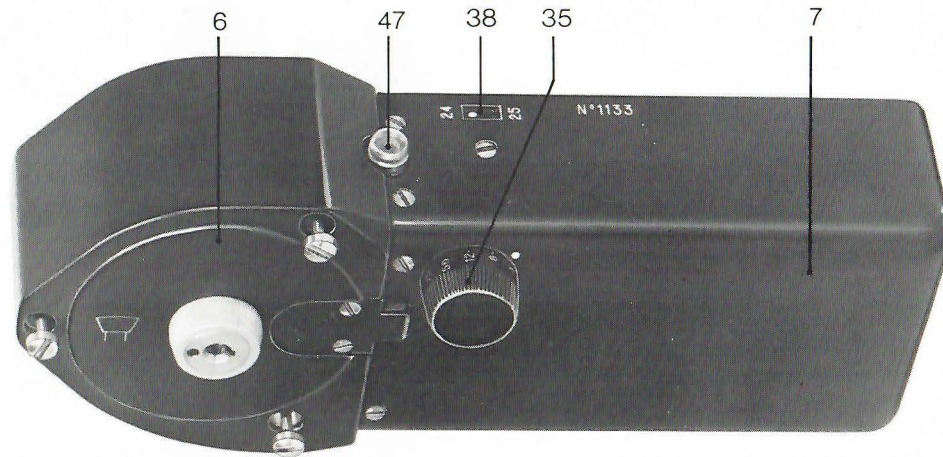

Fig. D. — Front part of the MIVAR.

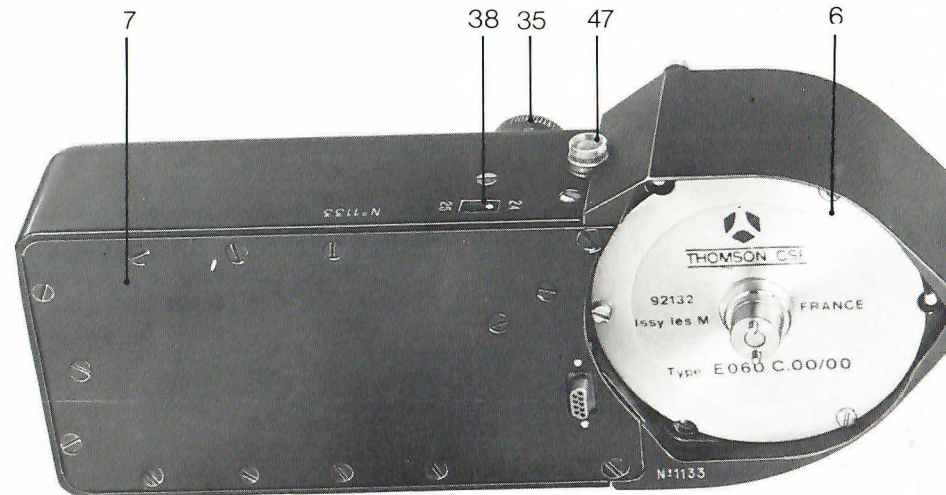

Fig. E. — Rear part of the MIVAR.

THE 60 m MAGAZINE

The two chambers of this snap-on co-axial magazine are separated by a median partition and are connected by a light tight ramp for the passage of the film from the feed side to the take-up side (Fig F).

THE 120 m MAGAZINE

Bearing in mind the versatility and light weight of the 60 m magazine which can be changed almost instantaneously, there are occasions where a « long take » in excess of 60 m is required and for this purpose a 120 m capacity magazine is available.

This co-axial magazine retains all the characteristics of simple threading and snap-on action for which the Eclair equipment is famous.

Slightly heavier than the 60 m magazine, its shape having been carefully studied permits a perfect rest on the shoulder (fig I) so that the handling and the stability of the camera are improved.

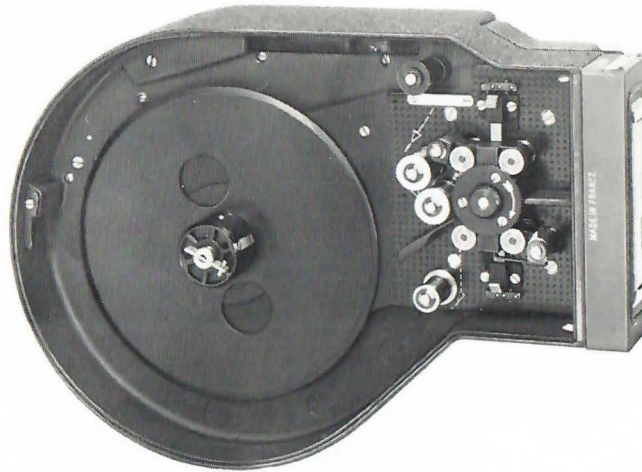

Fig. F



Fig. H



Fig. G



Fig. I

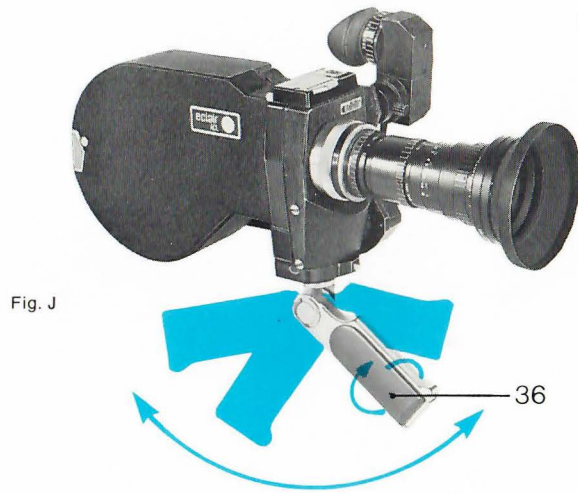

Fig. J

THE HAND-GRIP

The portability of the ACL is increased by the use of the hand-grip (36) supplied with the camera.

Adjustable in the horizontal and the vertical plane, it permits the choice of the most comfortable position. It can be screwed either under the camera base or on the right hand side of the camera (fig K).

To carry the camera, the hand-grip (36) with its knurled knob (79) - fig. QR - can also be screwed on top of the camera head.

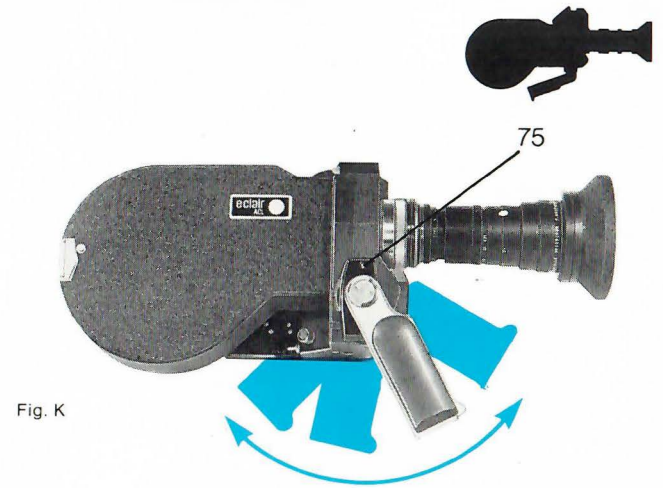

Fig. K

MOUNTS AND LENSES

The ACL has been designed to accept « C » mount lenses (fig L), the mechanical back focal distance of which are 17.52 mm, and also other professional mounts such as Eclair CA (fig M) Arriflex, Nikon, etc... the mechanical back focal distances of which are greater than 17.52 mm.

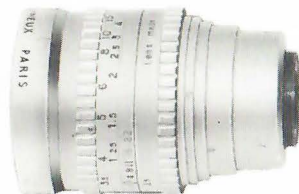

Fig. L

Lens in C mount



Fig. M

Zoom with CA Eclair mount

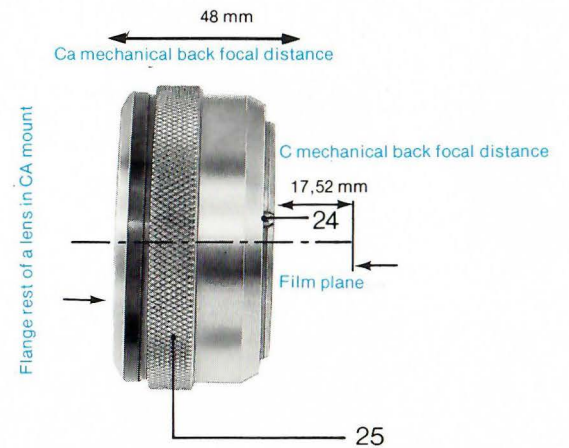

Fig. N

Intermediate mount

The mechanical back focal distances (fig N) being different according to the professional equipment manufacturers : 48 mm for ECLAIR (Eclair CA), 52 mm for Arriflex, 46 mm for Nikon, corresponding intermediate Eclair TS mounts (Fig P-P'-P'' —) can be supplied for these different makes of lenses for use with the ACL camera. For Arriflex, specify « normal mount » or « new steel bayonet mount ».

Hence, the ACL lens support (1) comprises an internal threading (21) the diameter and the thread pitch or which correspond to the C lenses standards and an external threading (22) for the Eclair TS mounts (Fig P-P'-P''); the orientation of the lens is ensured by the slot (23) at the top of the flange.



Fig. P
Intermediate mount
for lenses in CA mount



Fig. P'
Intermediate mount
for lenses in Arriflex mount



Fig. P''
Intermediate mount
for lenses in Nikon mount

ACCESSORIES

The principal additional accessories of an « ACL » equipment are :

- The 12 volts battery type VR 1,2 Code MIBAC
- The connection
cable camera/battery VR 1,2 MIBLE
- The rapid charger MIRAP
or
- The 12 volts battery type VR 4 BAKEL
- The connection
cable Camera/battery VR4 BABAC
- The compact charger CIBRE
- The connection
cable Charger/battery COURE
- The pilotone module MODUL
- The connection
cable Module/recorder
(according to the make of the recorder)
- The transport case MALAC

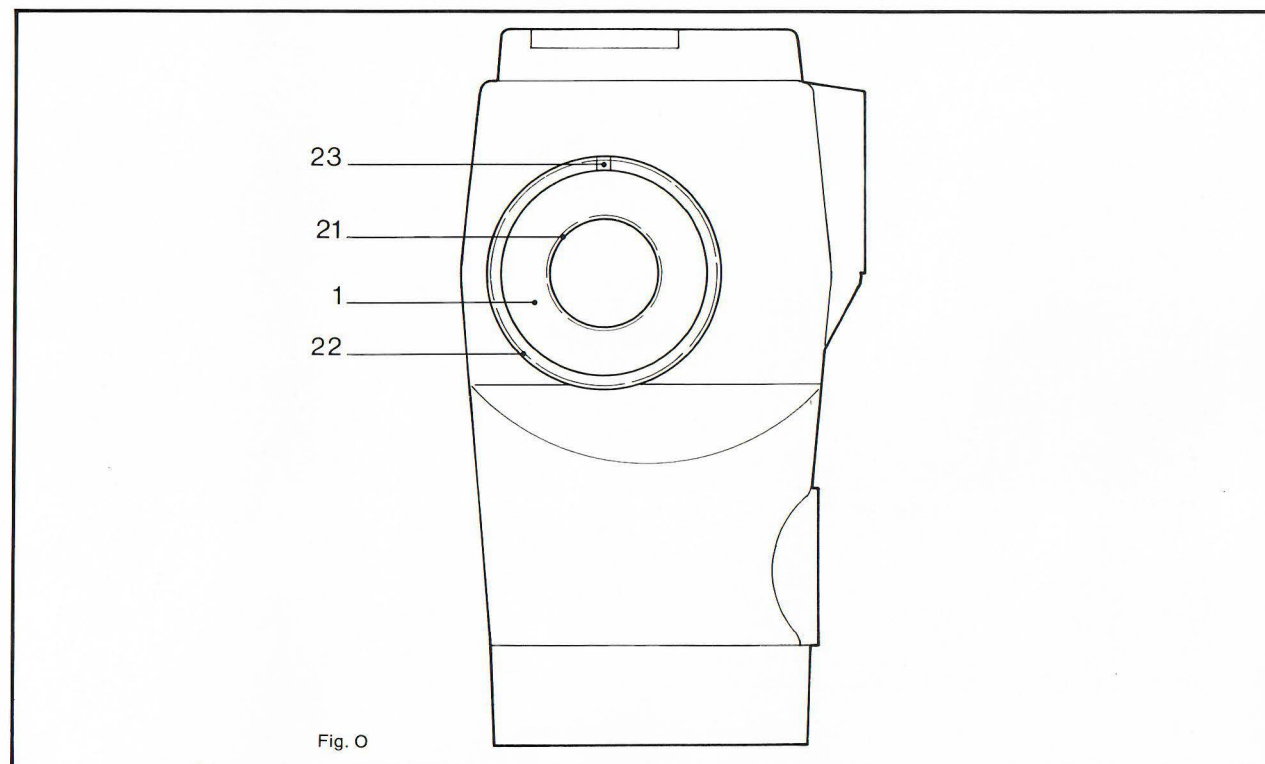

Fig. O

GENERAL INFORMATION

REFLEX SIGHT

The reflex image is obtained with an oscillating mirror (14) moving at half camera speed, which transmits the image formed by the lens onto the ground glass during the descent of the film.

The viewfinder (focussing tube) is a new mechanical/optical realization which gives an exceptionally bright image.

As on the Eclair 16, the ground glass gives a field of view greater than the recorded image, which eliminates the possible intrusion of microphones, etc... into the recorded picture. (Fig Q).

This viewfinder — 10 x enlargement — can be used for left eye or right eye viewing; it can pivot through 360° parallel to the camera thus allowing the cameraman to frame and to focus in the most comfortable conditions whatever the position of the camera; for example, he can shoot with his back facing the subject. The eyepiece is adjustable of ± 5 dioptries.

The standard ground glass is engraved with the 16 mm frame (10,2 x 7,4 mm), the TV frame and a cross in the centre (UER standard).

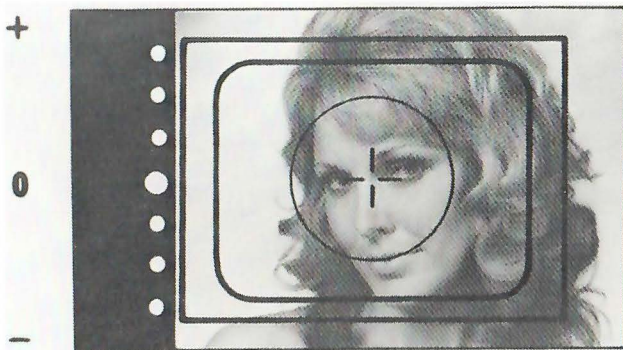

Fig. Q

Gelatine filter holder

Each ACL is equipped with a gelatine holder 2 (Fig A and R) which is located between the C mount and the reflex mirror close to the rear element of the taking lens. Its advantages are :

- It is not necessary to change filter at each lens change.
- It is possible to check the presence and type of gelatine through the viewfinder.
- It eliminates the requirement for front glass filters for each lens diameter, the price of which is very high compared to that of gelatine filters which are readily obtainable.

Fig. R



- Its position, away from the film plane ensures any small dust or finger marks on the gelatine that may occur are out of focus on the final result and rarely visible.

Shutter

Contrary to reflex cameras in which the mirror mounted at 45° acts as a shutter, the ACL has a plane shutter of large diameter completely independent of the mirror (14). It is placed very close to the film plane with an opening of 175°. Cutting the image in the direction of the smallest dimension gives a perfect exposure, maximum definition and reduction of jerky effect on some panning shots. The exposure time is 1/51 of a second at 25 frames per second and 1/49 of a second at 24 frames per second (page 33).



Mechanism

The complete silent mechanism is mounted on the mechanism plate which greatly reduces the time required for the normal overhaul and cleaning which we would strongly recommend to be carried out by one of our agents.

The claw movement (13) is controlled by an excentric and a fixed cam (39), the security is ensured by a counter-cam.

The four drive shafts run in self-lubricated bearings and the camera mechanism should NEVER be oiled.

As already indicated page (4), the aperture plate of hard chromium-plated steel has, on the left, a fixed guide (11) which is the edge reference for the film and a spring loaded guide (12) on the right, which maintains the film against the fixed guide.

The two guides (29-30) fig B position the magazine nose onto the mechanism plate.

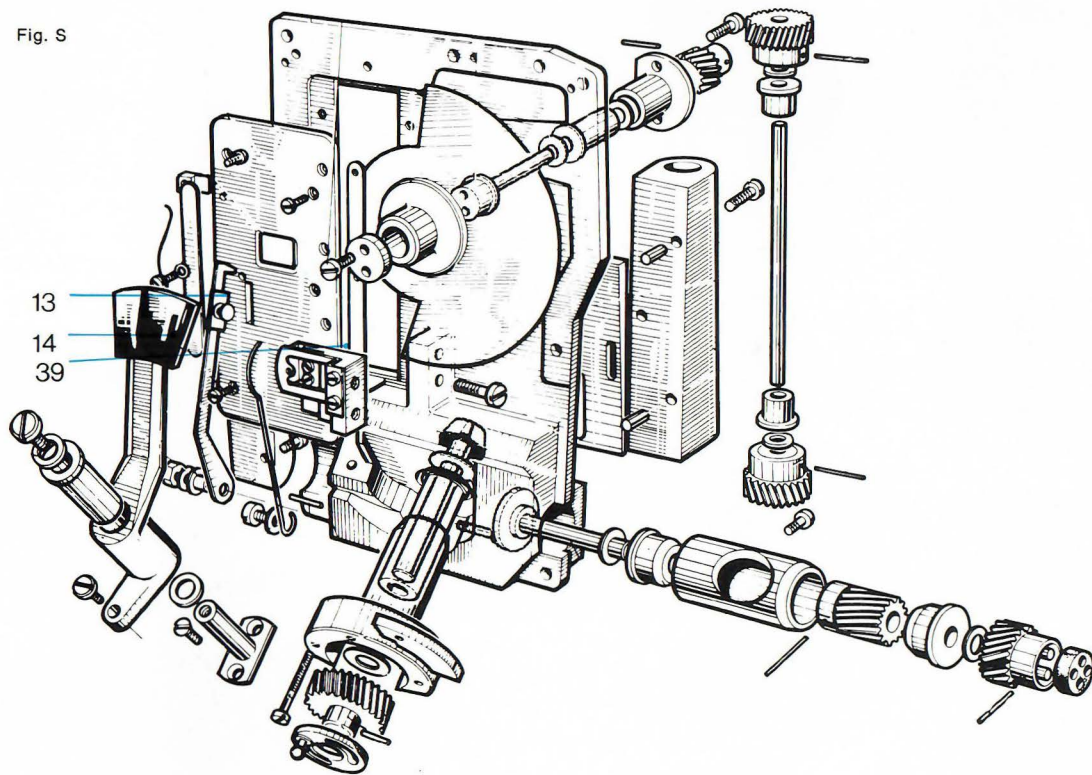

Exposure indicator

The ACL camera had to have a very safe « Exposure Indicator device » because of the professional work it must ensure. It could not be question of an ordinary photo-cell system due to the fragility of moving parts; on the other hand, a 100 % automatic device leaves the cameraman no chance of artistic creation.

The basic idea is to leave the cameraman freedom to determine the exposure of the film and thus give him the possibility of working according to his own technique; in other words he must have the possibility of

adjusting the diaphragm if he needs a special effect by under or over exposure, e.g. contrast.

Before filming, the operator sets the exposure indicator with the aid of his professional photo-cell exposure meter indicating the diaphragm opening (stop) of the lens; it gives him a reference lighting intensity « EO ». The camera being connected to the battery, he adjusts the sensitivity potentiometer (34) so that only the middle diode EO, visible in the viewfinder, lights up. Thus the camera is now matched to the exposure meter.

During filming, if the lighting intensity of the subject varies, the control diodes visible in the viewfinder will be seen light up either + or -. The operator will then correct the diaphragm of his lens so as to maintain the lighting intensity on the film to a value of EO, if he deems it necessary.

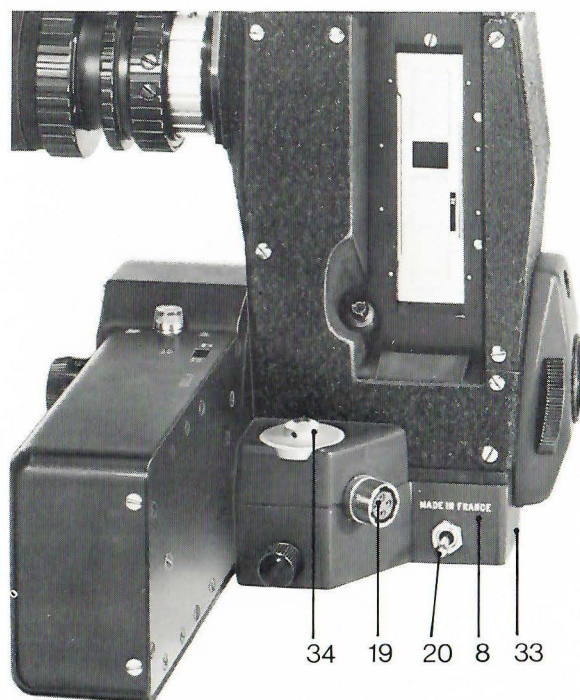

Fig. X



Magnetic recorder side
Fig. Y

ELECTRONIC BASE 150 E

This unit (8) forms a flat base for the camera body and consists of :

- 1 Jaeger socket (19) for power supply to the camera.
- 1 Sliding on/off switch (32) at the front part.
- 1 Cannon socket (33) for the accessory power supply.
- The stabilized 5 volt supply.
- 1 Souriau socket for electrical connections with the camera head.
- 1 sensitivity potentiometer (34) for adjustment of the exposure indicator.
- 1 Clapper switch (20).

This flat base is provided with the standard congress 3/8 tapped hole for tripod mounting or hand-grip mounting (36).

PILOTONE MODULE

The ACL servo-controlled crystal motor allows the shooting of sync. sound without any cable connection between the camera and the tape recorder if the latter is equipped with a crystal controlled motor (e.g. Nagra 4, Perfectone E P 6 A2, Stellavox). Such a system (diagram KL) does not permit the use of the clapper.

If, however, the two units : Camera and recorder are connected by a cable, the clapper will function (diagram L M). See additional information page 29 for connection and use.

When the recorder has no crystal, the synchronization can be ensured by using the Eclair pilotone-module (option) which contains its own signal.

THE ECLAIR PILOTONE MODULE is contained in a metal cover. Its size : 92 x 66 x 23 mm is slightly larger than a packet of 20 cigarettes (fig. Y and Z). It is a crystal pilot frequency generator 50-60 and 100 HZ.



Fig. X'



Camera side
Fig. Z

THE BATTERY (MIBAC)

The low torque of the camera and the high efficiency output of the motor have allowed the construction of a low power battery (1,2 amp-hour) which at 20°C (68°F) provides power for ten 60 m (200 ft) magazines i.e. for about 600 meter of film. This battery (37) weighs less than 1-4 lbs (640 grammes). It is a Saft type VR 1.2 ten cell cadmium-nickel which is enclosed in a polyurethane case (48) fig. AB.

The battery is equipped with a textile shoulder strap although its small size will allow it to be slipped into a coat or trousers pocket.

The connections with the camera and the pilotone-module can be made from either of the Jaeger 4 pin-sockets (49). The central Socapex socket (50) is provided for the rapid charger.

CABLE. The same type of cable (MIBLE) is required for connecting the camera, the battery and the pilotone-module. It is fitted with two Jaeger plugs ref : N° 530800.

Our V.R. mini-cell battery has been conceived for a recharge in less than 30 minutes by means of our MIRAP charger connected to the mains between 115 and 220 volts A.C.

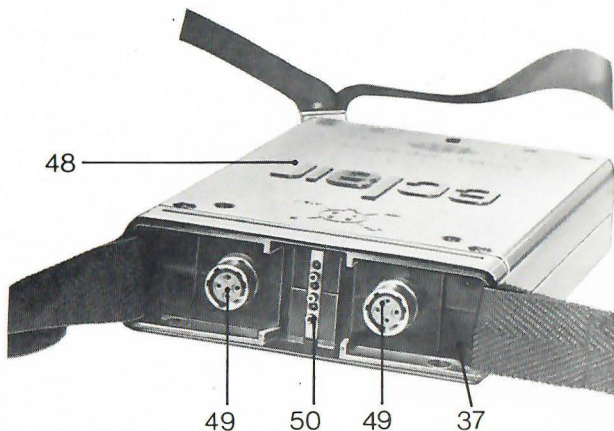

Fig. AB

THE CHARGER (MIRAP)

The MK2 charger specially made for our MIBAC battery is automatic and very simple to use.

It ensures a charge feed regulation of $\pm 20\%$ for a variation of the main supply tension of $\pm 10\%$. It stops the high speed automatically as soon as the battery has attained a tension which is related to the charge rate and the temperature of the battery.

The cut-off precision is approximately 1%. Immediately after the high speed charge has been cut-off, the charger switches automatically to the low charge rate.

The thermostatic protection is ensured by a thermal limiting device which cuts off the charge if the battery temperature becomes abnormally high e.g. because of irregularity in the cut off safety circuit

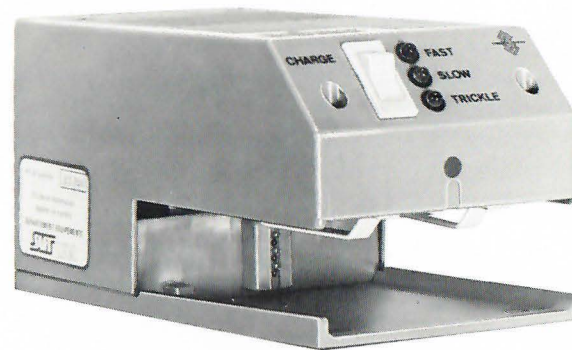

Fig. BC

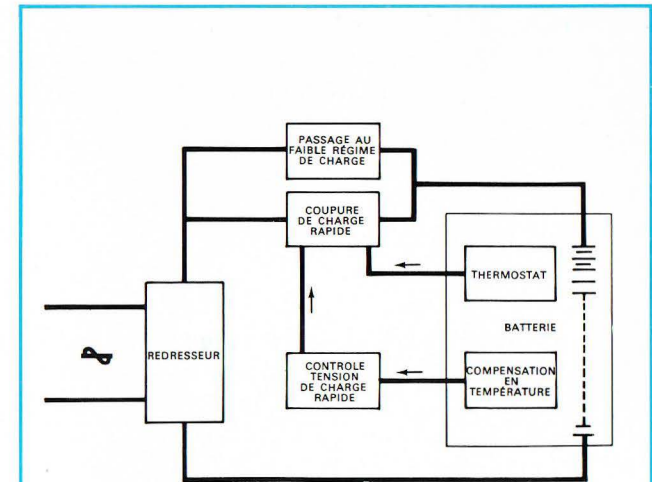

Diagram CD

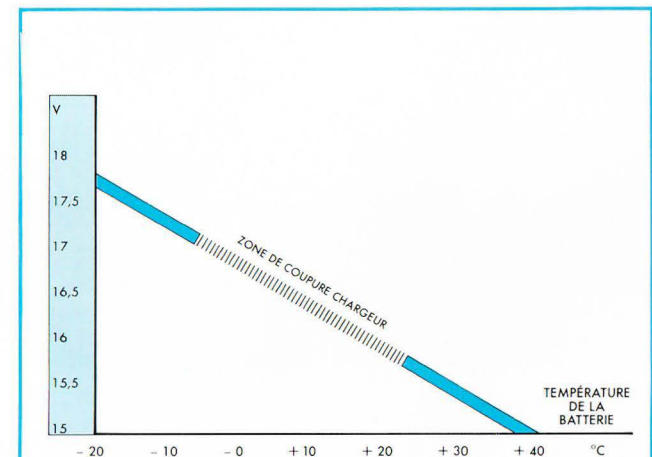

Diagram DE

BATTERY (BAKEL) CHARGER (CIBRE)

If a battery having a larger capacity than the MIBAC battery is desired, especially if the camera is often used at higher speed than the standard, we can supply the BAKEL battery (of the Eclair NPR 16) type VR 4 (4 amp-hour). It is a 12 volts cadmium-nickel battery — Fig EF — with a discharge controller (Schoeller galvanometer) and is supplied in a plastic box made of unbreakable black polyethylene with a carrying textile belt.

It is composed of 10 insulated cells SAFT type and weighs 1,650 kg; its dimensions are 230 × 150 × 40 mm and its capacity is equivalent to ten to fifteen 120 m (400 ft) reels. Its use necessitates a connection cable « Camera/ Battery » (BABAC), a 220/110 v - 12 V charger (CIBRE) and a connection cable « Charger-battery » (COURT).

The BAKEL battery can be also supplied in a leather belt with built-in charger, its code is BACHA. Its weight 2.750 Kg; only the connection cable « Camera/ Battery » (BABAC) is necessary.

The new compact charger CIBRE type 76 is very small : 125 × 64 × 40 mm and weighs only 420 grammes.

An internal tension selector permits its utilization on 220 or 110 volts; safety is ensured by a 500 mA fuse. A 2 metre connection cable « Main/ Charger » is supplied.

The CIBRE charger bears, at one end, a 3 pin socket (mains side) and at the other end a 4 pin Amphenol socket for connection to the battery; two control lamps : one red and one green light up as soon as the charger is connected to the main. The green light cuts off when the load is over.

To select the voltage in the charger (110 or 220 volts) or to replace the safety fuse, unscrew the 4 screws of the lid; take off the lid without dropping the screws, select the tension or replace the fuse, put the lid back and tighten the screws.



Fig. EF

Fig. FG



Fig. GH

CARRYING CASE

Made in shape of a rigid suit-case (fig GH) and not like an ordinary transport case, the framework is anodized aluminium supporting two shells in ABS which is a very high impact resistance material. The inside is entirely padded with expanded polyethylene cut out to the form of a complete ACL equipment : Camera with motor, viewfinder and 60 m or 120 m magazine mounted, extra 60 or 120 m. magazine, battery, charger, cables, pilotone module and miscellaneous (fig. HI).



Fig. HI

CABLES AND PLUGS

Taking into account the preceding information, will you please find hereafter diagrams that will help you to understand easily

the instruction manual; they will also help you should you have to order cables or plugs you may need.

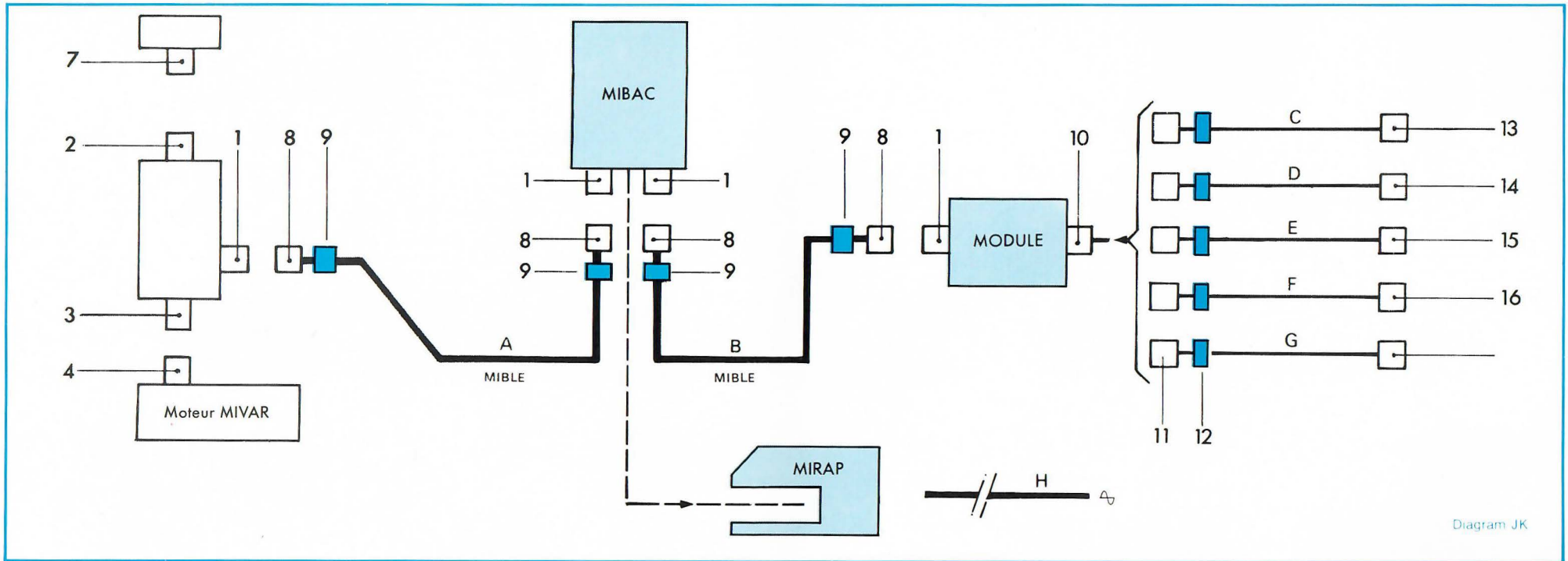

Diagram JK

- 1 - JAEGER female socket
- 2 - CANNON female plug
- 3 - CANNON female plug
- 4 - CANNON male plug
- 7 - CANNON male plug
- 8 - JAEGER male plug
- 9 - JAEGER cable flange
- 10 - JAEGER female socket
- 11 - JAEGER male plug
- 12 - JAEGER cleat
- 13 - TUCHEL plug
- 14 - TUCHEL plug
- 15 - Jack
- 16 - PREH plug

- 533800
- MDB 19 SH 031
- MD 19 SH 031
- MDB 19 PH 031
- MD 19 PH 031
- 530800
- 530332
- 533272
- 530273
- 530371
- 3401/1 ou /2
- 3300/1 ou /2
- PL 55
- 7140-4-250

- Camera-battery-module
- Camera
- Camera
- Motor
- Handgrip side support
- Mible feed cable
- Mible feed cable
- Module
- Sync. cable
- Sync. cable
- Sync. cable for NAGRA III
- Sync. cable for NAGRA IV
- Sync. cable for PERFECTONE EP6 A II
- Sync. cable for STELLAVOX

- A - Feed cable
- B - Connecting cable battery / camera
- C - Sync. cable Nagra iii
- D - Cable Nagra IV
- E - Sync. cable Perfectone EP6 A II
- F - Sync. cable Stellavox
- G - Sync. cable Uher (*)
- H - Feed cable mains to battery charger

(*) In case of « Uher 1000 Report » recorders, state the serial number of the machine.



UNITS CONNECTIONS

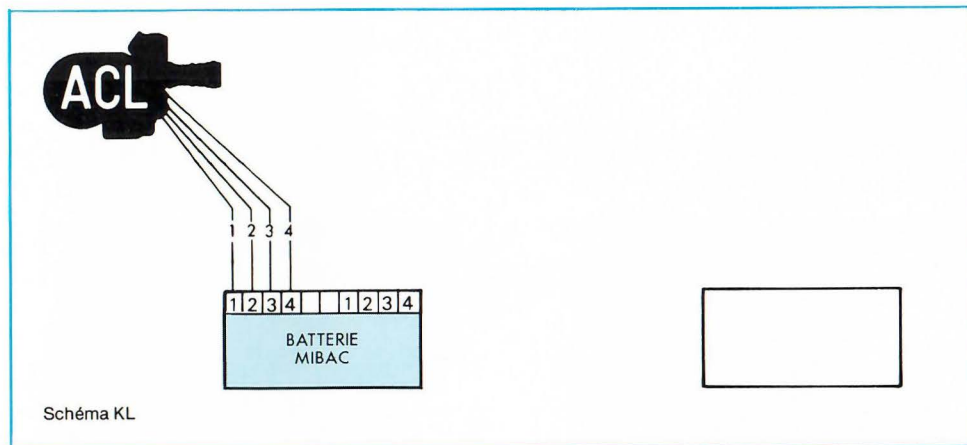

Equipment

- Camera with crystal controlled motor
- Recorder **with** crystal controlled motor

Possibilities

Sync. **without** connection cable
No clapper

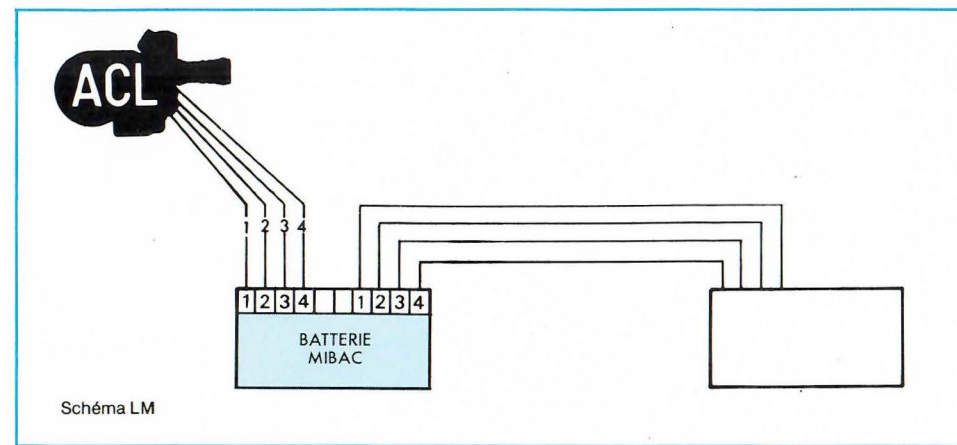

Equipment

- Camera with crystal controlled motor
- Recorder **with** crystal controlled motor

Possibilities

Sync. **with** connection cable
Clapper

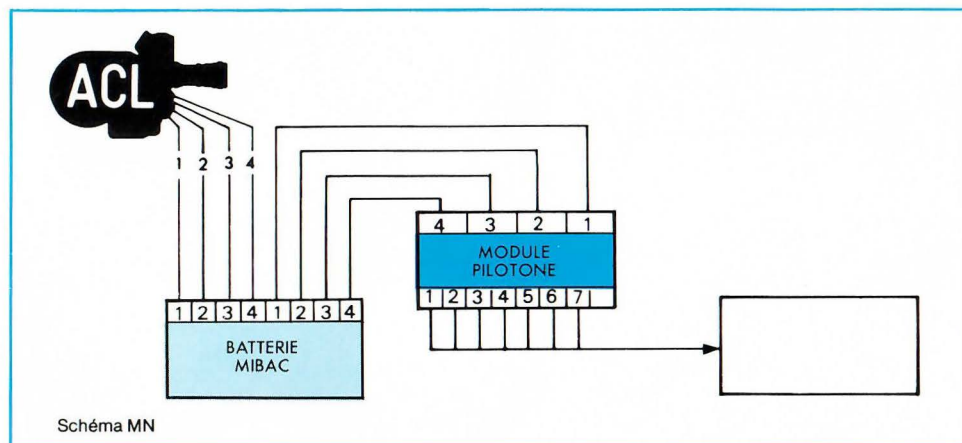

Equipment

- Camera with crystal controlled motor
- Recorder **without** crystal controlled motor
- Pilotone module fed by the camera battery

Possibilities

Sync. **with** connection cable
Clapper

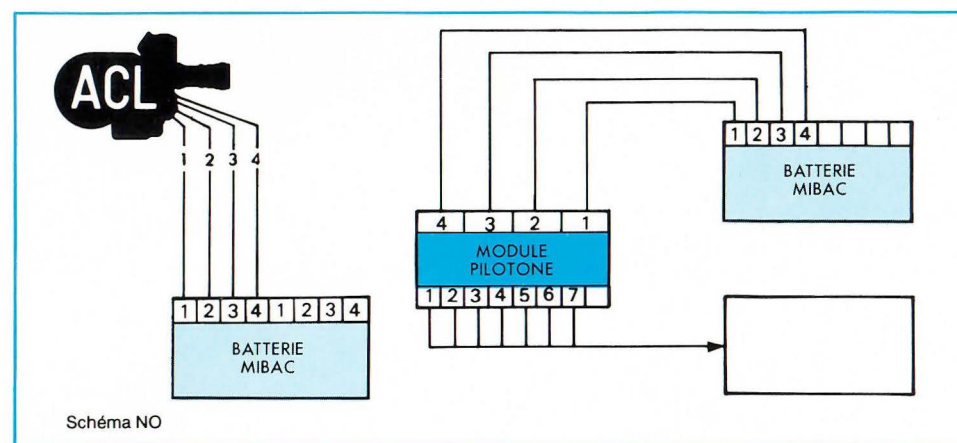

Equipments

- Camera with crystal controlled motor
- Recorder **without** crystal controlled motor
- Pilotone module fed by an external power supply : MIBAC 12 volts battery whenever possible

(shunt 3 and 4 by the Jaeger plug)

Possibilities

Sync. **without** connection cable
No clapper

INSTRUCTION MANUAL



2nd PART -

When you receive your equipment for the first time we recommend you examine every unit individually in accordance with the information given in this brochure.

After that, you will be able to follow the instructions for use more easily.

MOUNTING A "C" LENS

- Remove from the camera the protective cap of the lens mount.
- Remove from the lens the cap protecting the thread.
- Remove any dust from the flange with your finger.
- Screw in the lens in 21. Fig. 0.

If the distances and stops engraved on the lens barrel cannot be read by the cameraman in the normal operating position : take the lens off the camera.

The threaded ring at the bottom of the lens is mounted in contact with a special spring washer. Without touching the rear lens element, press down firmly on that threaded ring and turn it to modify the orientation of the distances and stop marks with respect to the thread start.

MOUNTING AN ECLAIR "CA" MOUNT LENS

- Remove the protective cap and the guard ring.
- Remove any dust from the flange with your finger.
- Locate the intermediate TS-CA mount (fig. P) on the lens support plate ensuring that the locating pin (24) enters the slot (23) of the flange.
- Screw up the retaining ring (25).
- Position the lens so that the slot (26) in the CA mount is vertical.
- Push the lens into the TS intermediate mount and lock by turning the lens clockwise.

As you will notice the Eclair intermediate TS mount is exceptionally robust with a large locating diameter and thrust face. The use of lens supports with the mount is not necessary.

It is strongly recommended that each zoom lens is fitted with an intermediate TS mount to prevent the deterioration of the limit stops on the lens after repeated locking in place on the camera.

DIOPTRY ADJUSTMENT OF THE VIEWFINDER

Legend of the external parts of the viewfinder :

- L1 - Eyepiece with shutter and rotatable rubber eyecup.
- L2 - Control ring of eyepiece shutter.
- L3 - Locking knob of the dioptre adjustment ring.
- L4 - 360° rotatable viewfinder unit.
- L5 - Eyepiece support with rocking motion for left and right eye sight.
- L6 - Locking ring of the rotation of the eyepiece support.
- L7 - Adjusting ring for partial positioning of the ground glass image.
- L8 - Clutch for final adjustment of the ground glass image.
- L9 - (Not explicitly defined in the legend, but shown in the diagram).

Everyone having a different keenness of sight, it is necessary for the camera user to set exactly and then lock the dioptre adjustment which corresponds to his vision.

This can be done **with** or **without** lens mounted on the camera.

Adjustment with a lens :

1. Place L5 to the right or to the left according to the eye you normally use.
2. Make sure that the reflex mirror is in the front of the aperture ; if not, turn knurled button 31 which controls the motor axle (see page 24, par. 5)
3. Turn control ring L2 to open the eyepiece shutter.
4. Focus the lens on ∞ (infinity).
5. Diaphragm wide open or slightly closed to darken the ground glass.
6. Loosen knob L3 and turn slowly in one way and in the other the dioptre control ring until the frame and cross engraved on the ground glass are perfectly sharp.
7. Take note of the number of dioptres in + or - that corresponds to your sight. Lock the dioptre control ring in that position by tightening the button L3.

This setting should always be kept as it will permit you to focus sharply at any distance.

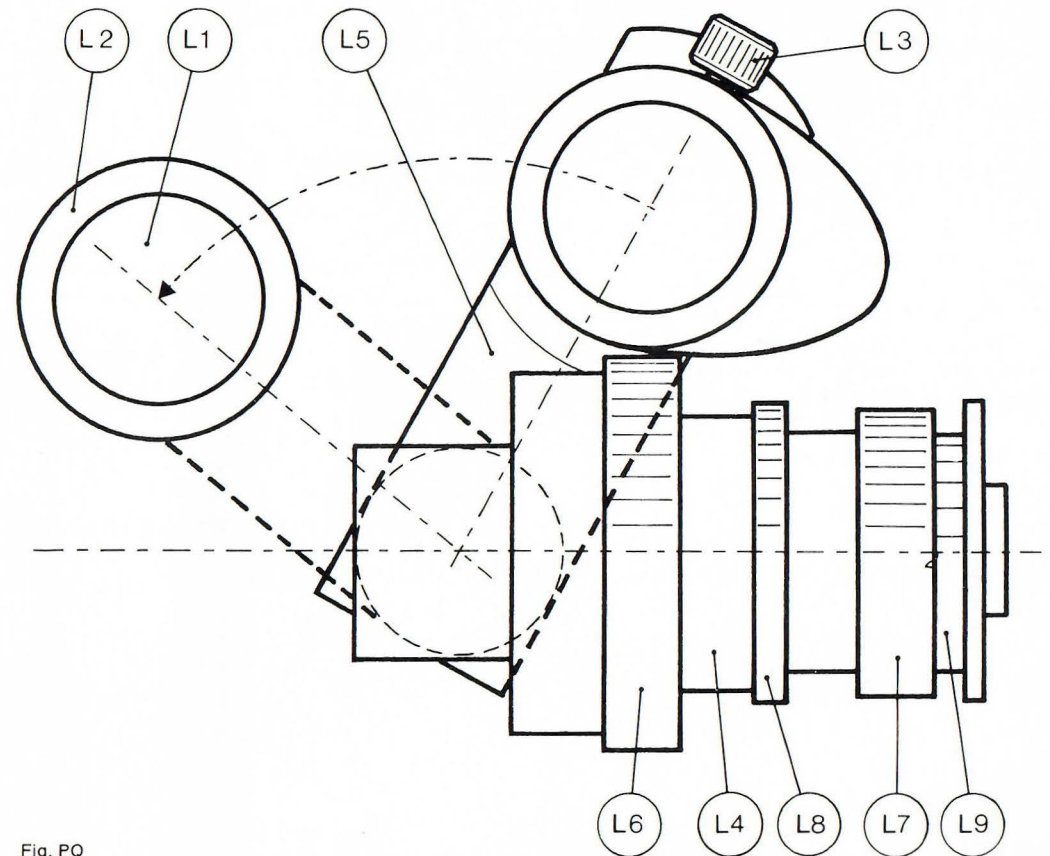

Fig. PQ

Adjustment without lens :

Direct the camera towards a well lighted part (sky, for example) and follow the preceding instruction 1-2-3-6- and 7.

Instruction for use

Position L5 for your left or your right eye, as needed. Make sure the dioptre adjustment is correct and the button L3 is perfectly tightened.

If the image on the ground glass is not optically horizontal, turn ring L7 in one way or the other to level the image. If you come to the thrust before the image is in the right position, turn L8 in the reverse way and move again L7. Once the image has been so erected the viewfinder can be pivoted through 360°, a Wollaston prism will keep it in the correct position.

If you shift L5 from left to right or vice-versa the image will reverse gradually until it is up side down; just turn L8 to declutch L7 and turn same to reset the image to its normal position. A positioning "clic-stop" is provided in L6 to set the eyepiece L1 in horizontal and vertical positions.

GELATINE HOLDER

Fitting a gelatine to the holder :

- Pull out the gelatine holder
- Open the holder by pressing the button (27)
- Place a 2" margin (50x50 mm) gelatine in the holder and close it.
- Cut the gelatine closely to the shape of the holder with a razor blade.
- Replace the holder in the camera, chamfered side forward.
- The correct positioning of the holder can be verified by checking that the aperture is concentric with the C mount aperture.

NB. Never place more than one gelatine in the holder.

Always film with the holder in place (with or without a gelatine) to avoid the possible fogging of the film.

The fact of filtering behind the rear element of the taking lens may cause a slight alteration of the focussing distances engraved on the lens which will be automatically compensated if focussing is done through the reflex viewfinder.

FITTING THE HANDGRIP

Under the camera :

- Screw the handgrip support — Fig. QR — into the electronic base using the knurled ring (27)
- Fix the handgrip (36) in the hole (80) of the support.
- Loosen the ring (79), set the position of the handgrip and tighten the ring (79).
- Loosen the half-moon (81), set the handgrip at the desired angle and retighten lock (81).

Onto the right hand side of the camera :

- Fix the handgrip (36) to the side support (75) and lock it in the best position by means of lock (81).

NB. The unit (79-80) — Fig. QR — is not used in this case.

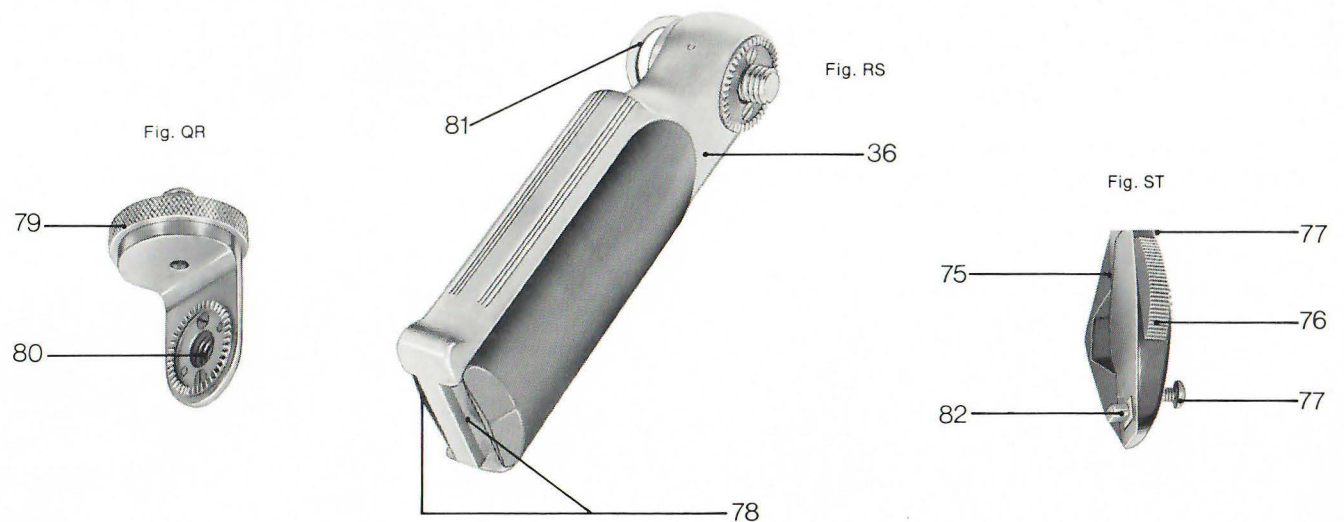

FUNCTIONS OF THE ELECTRONIC BASE 150 E

a) On/off switch (32)

This is a double action switch : it puts under tension the diodes of the exposure indicator, without starting the camera. Or it sends the power supply to the motor to start the camera. See page 24 detailed instruction.

b) The clapper switch (20)

In the central position this switch provides no clapper.

In outside right position : the clapper is automatic and provides fogging of the film for 0,3 seconds at each start.

In inside left position : the clapper functions (0,3 seconds) at every manual pressure when the camera is running ; this allows, for example, to clap at the end of filming, before switching off the motor.

Thus, the clapper ensures two functions :

- 1° - Automatic fogging of the film during 0,3 seconds at each start of the camera or manually at any moment.
- 2° - The supply of an 8 volt signal to the battery during 0,3 seconds (bloop) if the pilotone module is connected to the battery and the recorder, the signal triggers a 1 Kc signal on the recording tape.

c) The running signal :

A 12 volt signal available from the Jaeger socket supplies the pilotone module and ensures that the module only produces a 12 volt signal when the camera is running.

This signal can also be used to start a sound recorder from a distance.

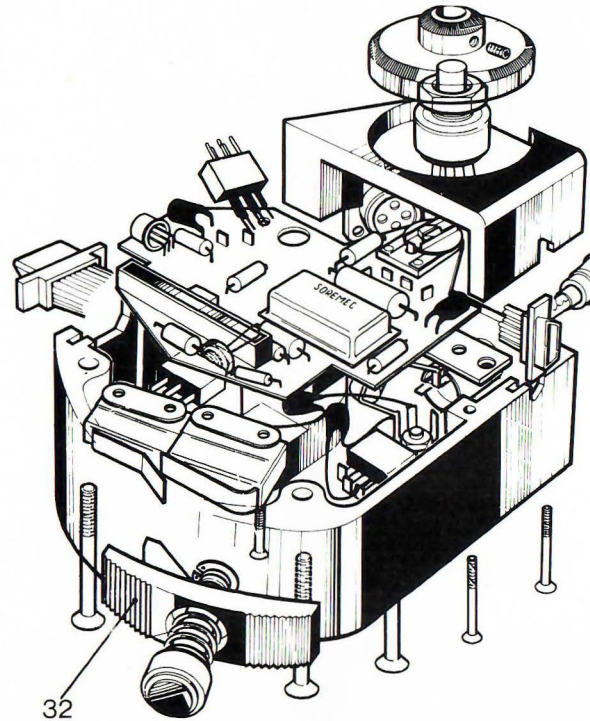

Fig. TU

d) The output signal :

1 - Tachometric signal :

This 3,8 volts square signal (peak to peak) is supplied by the motor. Its frequency is given by the motor speed multiplied by 40, that is to say 1000 Hz for 25 images per second and 960 Hz for 24 images per second. This signal directly supplied by the motor can be used for various purposes after it has been divided.

2 - Crystal signal (for MIALA motor only) :

This is a 100 mV sine signal (peak to peak). Its frequency is 1024 KHz for 25 frames per second and 983.04 KHz for 24 frames per second.



Schéma UV



Schéma VX

LOADING THE FILM

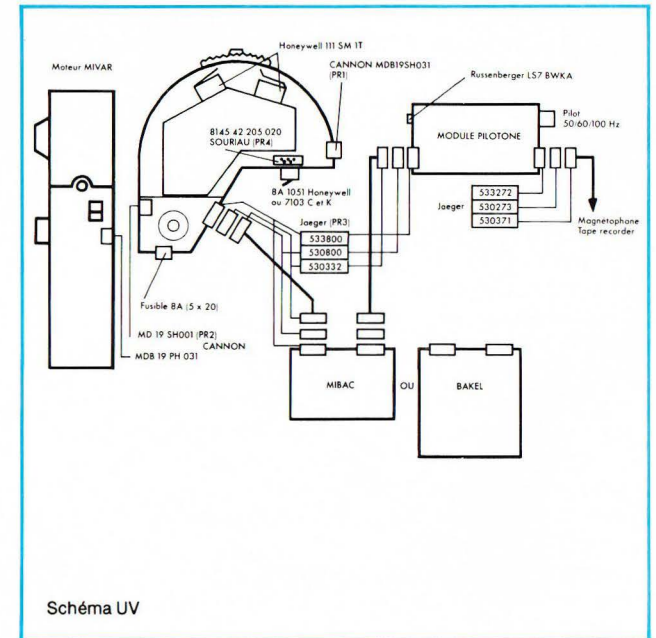
60 meter (200 ft) magazine :

To load a film on a 2" (50 mm) core, proceed as follows :

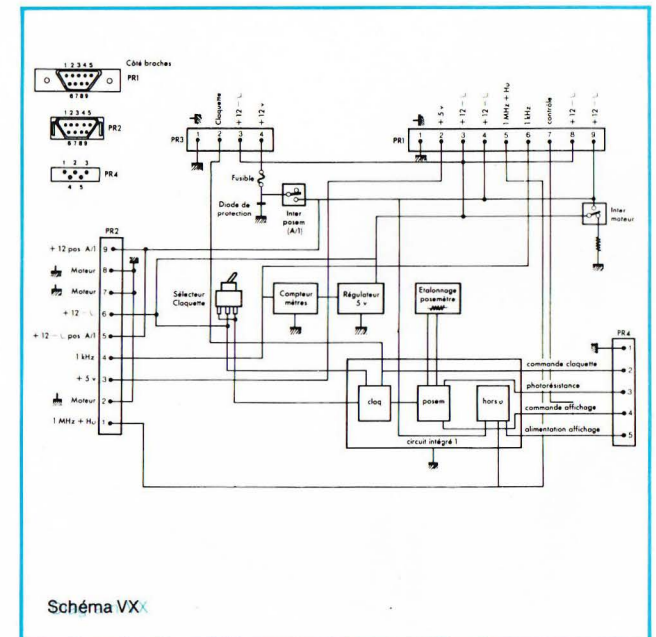
Feed side (fig. XY)

(to be done in a dark room or in a changing bag)

- Put the magazine on its side, nose to the left.
 - Depress the safety lock button and turn the lid catch anti-clockwise; lift the part of the latch that projects over the edge of the magazine. At the same time pull the lid backwards to clear it from the magazine.
 - Lift the counter arm (53) which locks up automatically.
 - Holding the film reel in the left hand position, feed the end of the film (about 30 cm) between the two rollers at the entry of the guide (54).
- Note :** the emulsion must be towards the exterior of the magazine between these rollers.
- Push approximately 15 cm (6") into the guide.
 - Place the core onto the support flange (55).
 - Replace the lid :
- insert the spring strip, at the left of the lid, into the magazine body (56), push the lid down and forward to locate it in the body and turn the lid catch clockwise to lock the lid.
- The counter arm (53) drops into place automatically as its catch (57) is released by the lid.

Take-up side (fig. YZ)

(this can be loaded in, preferably in the shade)

- Turn the magazine and lay it on its side with the nose (58) to the right.
- Remove the lid.
- Pass the film between the rollers (59) and (60) and place the end into the upper film guide (61) of the nose; if necessary press on the pressure guide (62) to aid the entry.
- Pull the film through sufficiently to introduce it into the lower film guide (63).
- Pull 50 cm (20") of film into the magazine.
- Open the two guide shoes (64-67) by pressing simultaneously the two catches (65).

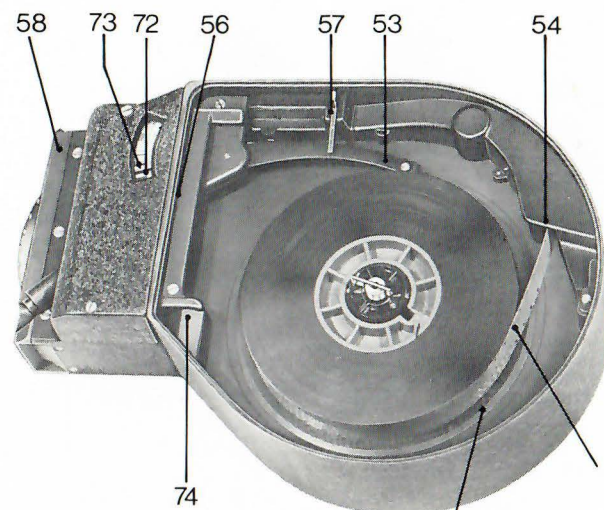

Fig. XY

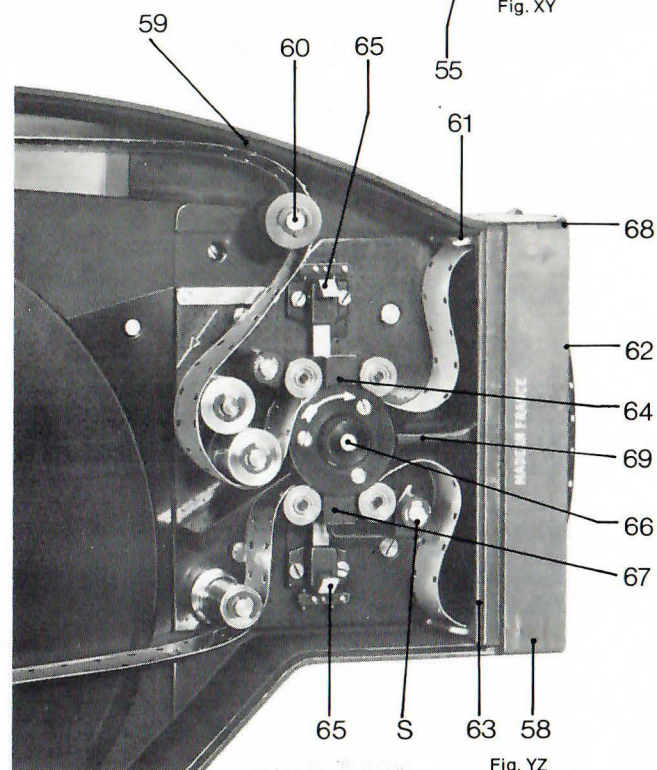
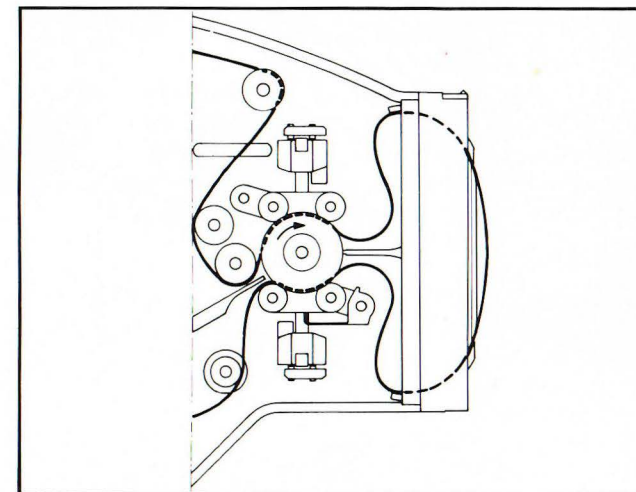

Fig. YZ

- Place the film behind the two rollers and between the sprocket (66) and the upper guide shoe; make sure that the sprocket teeth are perfectly engaged in the perforations.
- Close the upper shoe toward the sprocket; it locks automatically.
- Place the film between the sprocket and the lower shoes (67); adjust the loop size by pulling the film upwards outside the magazine until the loop is level with the magazine locking tongues (68). **This is important.**
- Close the lower shoe (67) against the sprocket and **divide the film equally over and under the film separator (69) in the magazine nose.**
- Wind the film onto the core and place it on the flange (70). This flange is interchangeable with flange (55).



- Replace the lid.
- Note :** the « S » part is an audible warning unit (see page 25).



Loading a daylight loading spool to the magazine

- Choose a shaded area if possible.
- Pull and lift vertically the flange catches (71) on the supply and take-up sides.
- Remove the flanges (70).
- Load the film as for a core load.
- Lock the spools in place with the catches (71) ensuring that they are pushed firmly home.

NB. In order to ensure the lowest noise level check that the spools are not warped and that they are firmly locked onto the axle as indicated above.

If it is not intended to use the magazine at once, place the protector on the nose.

The counter (72)

As already noted, the counter arm comes into operation automatically. The pointer (73) indicates the amount of unexposed film remaining; a red portion of the counter dial indicates the imminence of the end of film.

120 m (400 feet) magazine :

Loading the 120 m magazine in dark room on a 2" (50 mm) core :

Supply side

- Place the magazine, flat on a table, nose (58) to the left.
- To remove the lid, press on button (83) and turn downwards the white lock (84) for about 20 mm.
- Lift slightly the rear part of the lid and pull it to the right to disengage the spring which maintains the front part of the lid to the nose.
- Load the film according to the information given for the 60 m magazine.

Take-up side (fig. AC)

- Put the magazine, flat on a table, nose (58) to the right.
- Take-off the lid as per the supply side.
- Load the film as per a 60 m magazine.

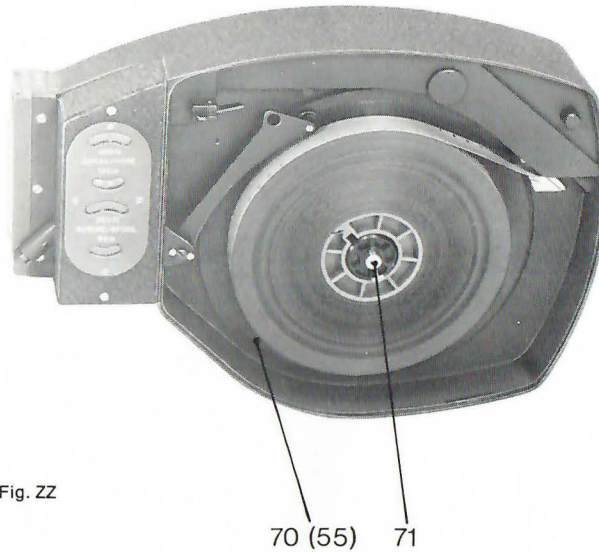

Fig. ZZ

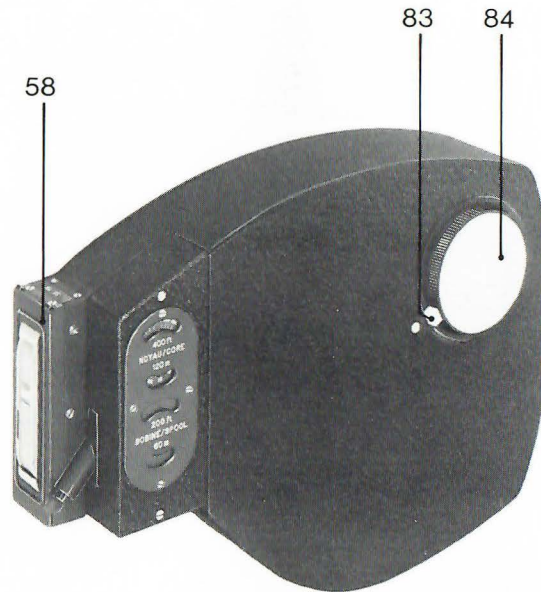

Fig. AC

Note - The same recommendations for the film loop must be applied.

Footage counter :

As in the 60 m magazine, the counter arm comes into operation automatically. Outside, on the feed side, two dials engraved in meters and in feet move in front of a guide mark and respectively indicate the amount of unexposed film used : either a 120 m reel on a 50 mm core or a 60 m daylight spool.



MOUNTING THE MAGAZINE ON THE CAMERA :

Before snapping on the magazine, check the loop and ensure that the aperture plate (10) is clean as well as the side guides (11-12), make sure that the pressure guide (12) is working correctly.

Make sure also that the outside loop of film is equalized (up and down) in front of the gate.

With the magazine tilted backwards (fig. G) place the lower part of the magazine nose at the bottom of the aperture plate, the magazine drives shafts (18-74) are aligned.

Pivot the magazine on its locating points and push it at home. The lock operates automatically and a sharp click indicates that the magazine is firmly in place.

The safety catch 17 of the lock 16 will avert accidental disconnection of the magazine that could be caused by a chance manipulation of lock 16.

To remove the magazine :

- Hold the magazine by the top, the camera being supported by the other hand.
- Lift up the safety catch 17 with the top of the forefinger.
- Press on lock 16 with the forefinger.
- Pull the magazine down and back to clear it from the camera.

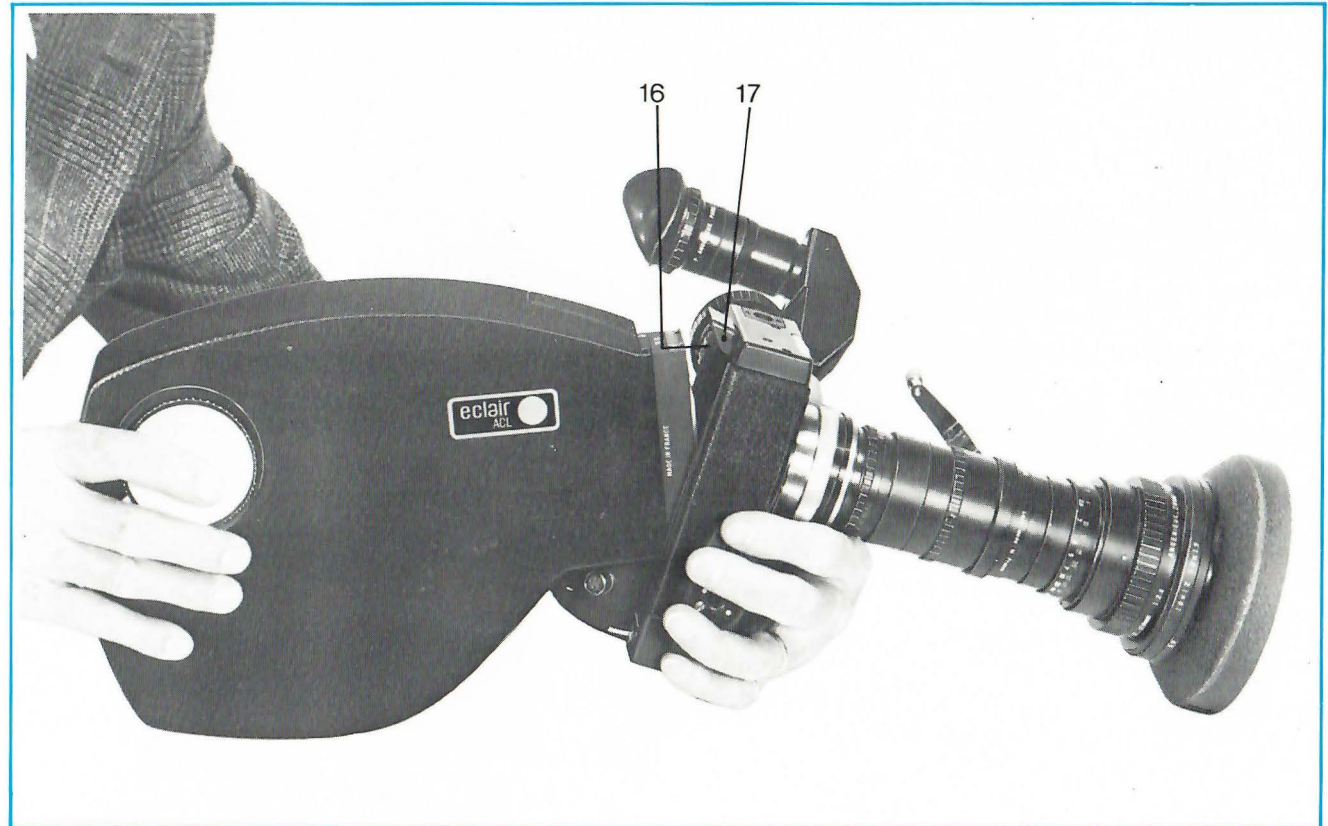

Fig. G

STARTING THE CAMERA

Having fitted a lens and the magazine on the camera and checked the dioptre adjustment of the viewfinder :

- Attach the battery to the camera with the cable MIBLE (or with the cable BABAC if you are using a BAKEL battery).
- Make sure that the motor has been set at the right speed : for 24 frames per second, move the switch (38) to the right so that the white spot will be in front of 24. Turn the knob 35 so the letter N faces the datum mark. For 25 f.p.s., move the switch (38) to the left to have the white spot in front of 25; the knob 35 should be placed as indicated above, i.e. « N » in front of the datum mark.
- For other speeds : 8-12-50 and 75 f.p.s. place the desired speed engraved on the knob 35 in front of the datum mark.
- Frame and focus through the viewfinder. If, by chance the reflex mirror is not in the viewing position, adjust it by turning the knurled knob (31) anti-clockwise. Normally, the MIVAR motor always stops the camera in viewing position (page 5 par. 3).
- Set the clapper switch to the required position :
 - central : no clapper
 - right : automatic clapper at each start.
 - manuel clapper is operated when the switch is moved to the left (see page 27).

Start the camera by pushing the button (32) in and sliding it to the left-position-3- (towards the motor) or by moving the side micro-switch 76 upward after the button 32 has been pushed to the right-position 2-.

- The stop in viewing position (shutter in front of aperture) is automatically obtained if the micro-switch 76 has been used. It is also obtained if the switch 32 is brought back from position 3 « run » to position 4 « stop ».
- When the camera has been stopped by the switch 32, from position 3 to position 1, the reflex may not completely cover the aperture; turn knob 31 anti-clokwise.
- When the camera has been stopped, the warning light 47 on the motor body remains lit a few seconds and then goes out. If this lamp lights up during filming, it indicates the battery is flat or motor is out of phase.

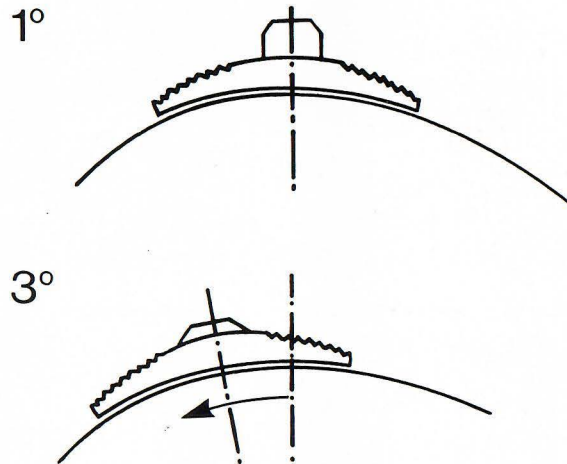

It is important to resume the 4 functions of the switch 32 on an ACL equipped with electronic base 150 E incorporating the Exposure indicator.

Pos. 1. The switch (32) being in central position is « off » position. When depressing the button (test position), the exposure indicator is put under tension and the LED diodes light up.

Pos. 2. When sliding the switch (32) to the right, (looking through viewfinder) the test position is retained (camera stopped) for determination of the diaphragm stop.

The starting and the automatic stop in viewing position can be obtained by the switch 76.

Pos. 3. The switch 32 being slid to the left starts the camera and the LED remain illuminated.

Pos. 4. The switch 32 being slid back to the right, the LED remain illuminated and the shutter will stop in viewing position.

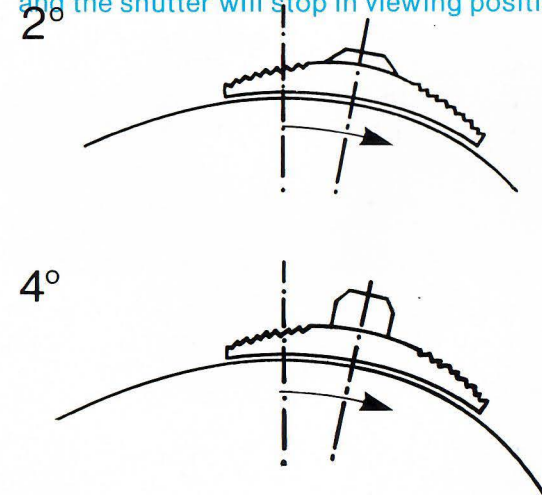

Fig. CE

Audible warning device in magazine :

This system S (fig. YZ) also called « ghost indicator » functions if the film loop is resorbed ; it produces a clicking sound which warns the cameraman.

In that case :

- Stop the camera and remove the magazine.
- Check the loop and divide it normally.
- Re-mount the magazine on to the camera.
- Restart the camera.

Should this occur again, check in a changing bag the threading of the magazine ; you will probably find a film jamming due to some damaged perforations.

EXPOSURE INDICATOR

This being temperature compensated (— 25° to + 60 °C) the setting remains constant for several weeks.

The measuring system and display assembly is situated immediatly next to the ground glass, supporting the viewfinder frame (fig. T).

A resolving prism (01) which is semi-reflecting is stuck to the prism block (02) and refracts part of the light rays emerging from the ground glass towards the photo resistive element (03).

The light intensity received by the photo resistive element is compared with the reference determined by the gauge, and intensity already memorised by the computer (fig. U). The seven diodes are mounted on a ceramic base situated next to the ground glass, outside the field of view (fig. T) ; they indicate the zero or the difference in aperture (either + or —). The maximum recordable difference is ± 1.5 stops, each diode representing about one half stop (fig. U).

Characteristics

- Type of photometer : to adjust by comparison manual setting of aperture ring.
- Type of measurement : behind the lens (T.T.L.) semi-spot 4 mm dia, angle 10° with F. 25 mm semi-spot 7 mm dia, balanced at 50 %.
- Sensitivity range : 25 to 400 ASA.
- Sensing element : rapid response C D S cell. compensated sensitivity range.
- Display : 7 Light emissive diodes (LED) resolution interval, 0,5 dia/1 dia/1.5 diaphragm.
- Light computation : resolving prism (= 25 % on the CDS cell) neutralising the semi-reflective deposits.
- Compensation Stop-go : electronic compensation ; automatic compensation.

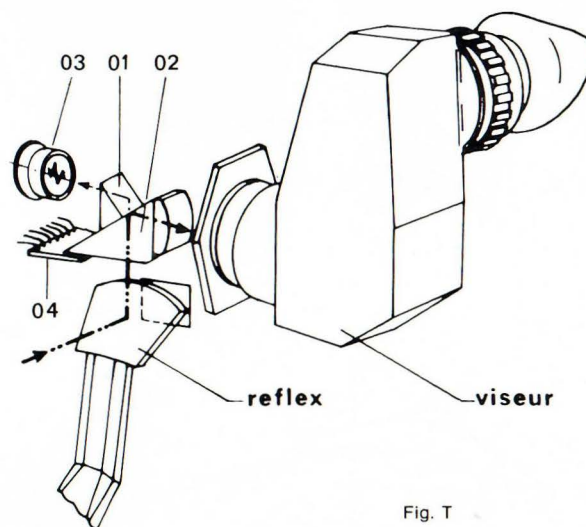

Fig. T

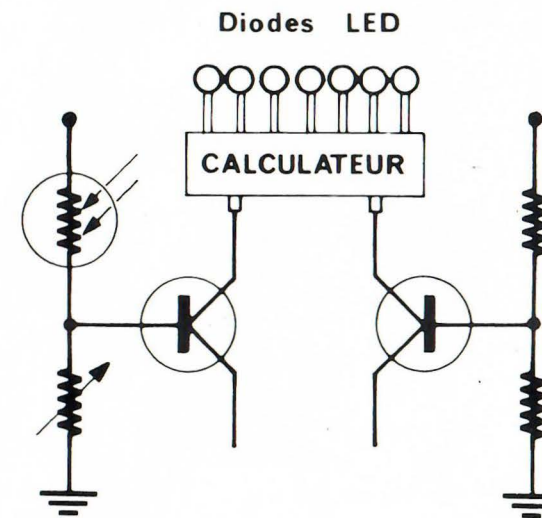

Fig. U

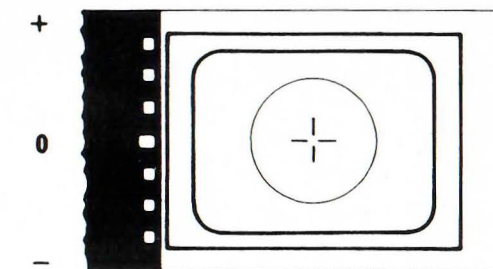

Fig. V



Advantages of the system

- Compactness of the measuring assembly and display situated next to the ground glass : This lay out requires the minimum of optical components, no reflection, no intermediate optics, (no risk of misalignment).

- System of setting up by comparison :

No setting imposed by the manufacturer, the operator is the judge of the optimum lighting for the film.

No variable density disc, no compensation for non-linearity of the CDS cell response.

No corrections to be made on the sensitivity adjustment in spite of ageing and the history of the CDS cell.

- **Application of LED :**

Unlimited life for the whole unit (even when subjected to heftier shocks that is likely to occur to the system during transportation)

No light reflecting device to be indicated by a lively balanced pointer.
Constant light emission from the L.E.D.'s.

- Seven diodes : one central zero and six indicating + 0,5 stop, 1 stop, 1.5 stop
— 0,5 stop, 1 stop, 1.5 stop

- Progressive lighting up of the diodes (one, two, three) ensures a positive indication of difference in exposure.

INSTRUCTIONS FOR USE :

1° Setting up :

- Connect the battery to the camera.
- Look in the viewfinder to make sure the camera is in viewing position (mirror in front of aperture).

- Move the switch (32) to the right. The diodes will light up (camera stopped).

Determine with your light meter, the setting of your diaphragm taking into account the speed of the emulsion and the filming speed.

- Adjust your lens according to the setting indicated by your light meter (f. 5.6 for example).

- Looking through the viewfinder, turn with one finger of the right hand the sensitivity potentiometer 34 one way or the other so that only the central diode lights up.
This being done, your camera is now set up.

2° Filming

Obviously, for keeping a normal exposure, the central diode **only** must be lighted. If the lighting intensity of the object varies, the control diodes will be seen lit up either + or —, visible in the viewfinder ; this will indicate that you overexpose or underexpose. The operator will then adjust his diaphragm by closing or opening it accordingly to come back to the normal exposure which will be shown by the illumination of the central diode only. In effect the operator has a continuous indication of light variations to within plus or minus 1 1/2 stops from the normal exposure and which he can vary at will (eg. for contrast effects).

MIBAC BATTERY

To plug in a Jaeger plug simply turn and push the plug onto the socket until the locking ring clicks into place. To remove the plug, pull on the ridged ring.

MIRAP BATTERY CHARGER

It might be useful here to give a simple outline of the operation of the rapid charge system : when recharging a battery with a current in the order of C 5 Amps a clear and reproducible increase in voltage becomes apparent towards the end of the charge, whatever the initial level of charge of the battery. It is thus possible to cut off the high charge rate and pass automatically to the low charge rate (the voltage increases as the charge rate increases) and also the temperature of the battery (the voltage increases as the temperature descends).

It should be noted that the most favorable charge rate for the ACL battery is 2 C 5 A and that a recharge can be accomplished with a **battery** temperature between $- 20^{\circ}\text{C}$ and $+ 40^{\circ}\text{C}$. The batteries are equipped with a group of silicon diodes in low series resistance and this system compensates for variations in temperature which might otherwise affect the charge cut-off voltage. The graph DE page 12 represents the law governing the variation in charge cut-off voltage with respect to temperature.

The capacity obtained after a high speed charge is very satisfactory (500 cycles 800 mAh) but does not give the maximum possible capacity which can be obtained by proceeding the charge at a lower rate.

The MIRAP charger is provided with a switch permitting the choice between the rapid charge FAST (red diode) and the slow charge SLOW (yellow diode). At the end of the charge, it passes automatically on the maintenance charge TRICKLE (green diode).

The slow charge increases the life of the battery.

Operation

Plug the cable into the socket (51) — fig DF — at the rear of the charger taking care to position it correctly for the corresponding voltage : 117 volts or 220 volts A.C. 50 cycles or 115 volts AC 60 cycles. Plug the other end into the power supply using a plug corresponding to the mains supply socket. This connecting cable is provided with an earth wire which is yellow/green in compliance with the international standard.

Insert the battery into the charger, the red point on top facing the red point which is on the charger. If the battery is correctly pushed in place, its plug (50 — fig AB —) enters the socket of the charger and the control lamp lights up. The charge will not take place if the two red marks do not coincide. — fig EG —.

The consumption is 1,3 Amp at 220 volts.

When the battery is fully charged the signal lamp will go out.

The ensemble — charger / battery — may be left indefinitely connected to the main, without any danger. On the other hand, never leave a battery in the charger if the latter is not connected to the main because the battery will discharge.

A safety fuse 52 of 800 milli-amp. protects the charger ; it blows in case of excessive voltage increase. Two spare fuses are stored in the two rear feet of the charger — fig FH —

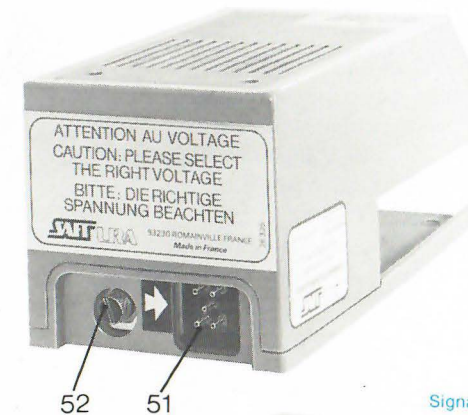

Fig. DF



Fig. EG

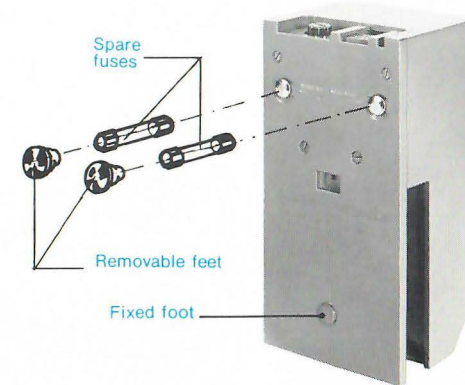

Fig. FH

BAKEL BATTERY CIBRE CHARGER

The BAKEL battery — fig GI — the principal characteristics of which are described page 13, is always supplied discharged after a complete cycle of charge and discharge.

The technical characteristics of the CIBRE charger — fig HJ — are :

- Dimensions : 125 × 64 × 40 mm
- Power supply : 115 or 220 volts AC by voltage selector, 50 or 60 cycles.
- Weight : 0,420 kg.
- Safety : fuse on the alternating current, type 01 0,25 amp.
- Rate of charge : 320 mA.

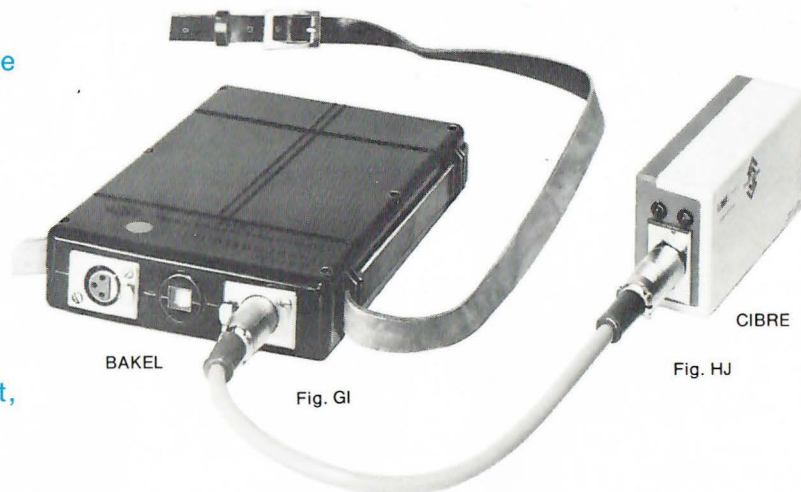

Charge

According to the mains supply 115 or 220 V., connect the charger to the mains by means of the cable; the two indicator lamps light up.

Connect the 4 pin Cannon sockets of the battery to the charger by means of the CICAB cable.

Charge for 14 hours.

The green indicator lamp goes out at the end of the charge.

Partial charge

Very often the battery will be recharged before having been fully utilized; the following table indicates the charging time necessary :

Number of 120 m magazines used	2	3	6	12	or more
Number of hours of charge	3	6	8	16	

Charge indicator

Discharged battery : the pointer is in the red area.

Charged battery : the pointer is in the middle of the white area.

If, while the camera is operating, the pointer is between the two areas (for an 11.5 voltage) the battery will only last for one or two 120 m magazines.

Never use a part section of the battery as the cells would become unbalanced and the polarity of some of them could be reversed.

Maintenance

No maintenance is necessary. Check to wiring from time to time. Never alter it. However, if a battery does not hold its charge, or if the duration of its performances reduces, it should undergo the following operation :

- discharge the complete battery down to 9 volts.
- discharge each cell using a 1-Ohm resistance inserted between the terminals, down to 0 volt.
- let the cells stand for one hour.
- recharge the battery for 18 hours.

If then the battery has not regained its full performance it is because one of the cells has been damaged and must be changed. A new cell can be inserted into the battery only under the condition that **all** the cells have a zero voltage.

ACCESSORIES

PILOTONE MODULE

As already said, this accessory is a crystal pilot frequency generator 50-60 and 100 hz. Its precision is $\pm 510^5$ within a temperature limit of $- 20^{\circ}\text{C}$ to $+ 60^{\circ}\text{C}$ ($- 4^{\circ}\text{F}$ to $+ 140^{\circ}\text{F}$). The output tension is 1 v. effective.

A three position switch 50-60-100 selects the pilot frequency recorded on the magnetic tape corresponding to the standard used when transferring the sound to 16 or 35 mm perforated film.

Our pilotone-module provides two possibilities :

1. If the clapper is required : connection by cable (diagram MN) of the image units (camera/battery) to the sound units (recorder/pilotone module), the MIBAC camera battery supplies the pilotone module. The cable allows the operation of the pilotone module when the camera is running and the recording of the « bloop » information on the magnetic tape. This associates the crystal generator regularity with the automatic clapper advantages.

2. If no clapper is needed : working without a connection cable between the image units and the sound units (diagram N.O.). In this case, supply of the pilotone module must be ensured by a second MIBAC battery, the first one feeding the camera.

GELATINE HOLDER WALLET

Designed for five gelatine holders (in supplement to that in the camera and the two included in the standard handgrip) the wallet gives the possibility of having a set of filters to cover conditions that might be encountered during filming.

MAINTENANCE RECOMMANDATIONS

If there are deposits in the gate (10) (channel) particularly along the side pressure bars, remove them carefully with a tooth pick or preferably a manicure orange stick. Never use any metal object.

It is important that the spring load pressure guide (12) and the pressure plate of the magazine (62) operate smoothly and freely. If they do not work satisfactorily the equipment should be returned to the supplier for adjusting.

Avoid the use of brushes since they are generally dirty and have loose hairs. If a hair is caught in the claw slot it may damage the movement ; if it is caught in the aperture it will very likely appear on the projection of the film.

Using a clean chamois leather occasionally moistened a **small amount of alcohol** clean the plate, rubbing up and down. Care should be taken not to catch the claw (13) with the chamois.

CLEANING THE MAGAZINE

The sprocket drum and the pressure plate roller-guides may be cleaned with a fluff cloth slightly moistened with alcohol. For the interior it is preferable to use an air syringe.

For the optical parts use an air syringe. Any other cleaning, even with optical or above all tissue paper, could slightly scratch the surfaces.



AFTER SALES SERVICE

As all cinematographic equipment for professional users, a general overhaul carried out from time to time by the maintenance service of your supplier will avoid troubles and waste of time and money.

The spare parts catalogue N° 7011 shows the ACL in the form of exploded diagrams that illustrate the location of all the components that go to make up the camera, motor and magazines.

INSPECTION AND REPAIR TOOL KIT

A full set of tools is available for the work necessary to keep the ACL in tip-top condition.

The catalogue N° 7011 and a maintenance booklet are available, on request, to all users who have at their disposal a repair workshop for the cameras.

CHANGING THE MOTOR

If you must replace your motor, please proceed as follows :

Removal :

- Disconnect the battery from the camera before this operation is carried out.
- Take the lens off the camera.
- Turn the knurled knob 31 to bring the reflex mirror in the aperture centre. In this position the screw 46 of the knurled knob 31 of the motor is adjacent to the guide mark  engraved on the motor casing — fig IK — ; this position vertically the two driving spigots 42 of the motor — fig JL — and the two corresponding holes of the camera rubber driver (41) — fig KM —.
- Undo the three captive screws (40) with a screwdriver or a coin and pull the motor out along its drive axis.

NOTE. For checking purpose, the bottom screw (40) is sealed. Take the seal off with a small screwdriver or a small pointed tool to allow access to the screw.

Replacement :

- Make sure that the screw 46 of the knurled knob 31 is perfectly in line with the guide mark  and that the reflex mirror is in the centre of the aperture.

Align the camera plug (44) on the motor with its socket (45) on the camera and push the motor into place along its drive axis — fig JL and KM—.

The two drive spigots (42) on the motor must be perfectly in place in the two holes of the camera rubber driver 41.

- Tighten the three screws 40.
- Check that the drive is correctly engaged by turning the knurled knob (31) anti-clockwise. It should run freely.
- Re-connect the battery.

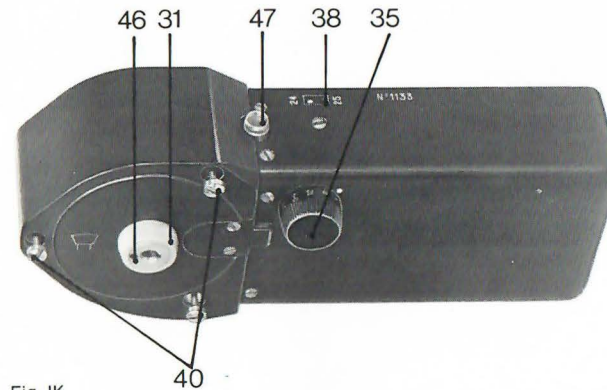

Fig. IK

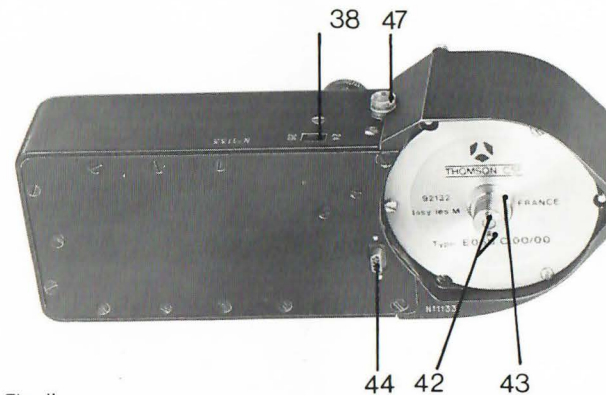

Fig. JL

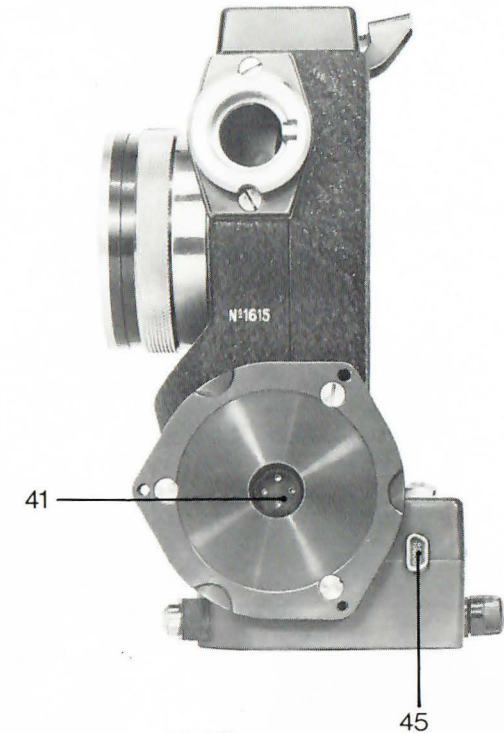

Fig. KM

RECOMMENDATIONS FOR USING OUR CAMERAS UNDER EXTREME CLIMATIC CONDITIONS

FILM AND TEMPERATURE

Storage

The package in metal cans conserves the sensitometric and mechanical characteristics of the film (raw stock material). On the following table, we indicate the maximum temperatures for storage not exceeding a period of 6 months.

Black & white negative film 12 °C = 53 °F.
Black & white positive film 18 °C = 64 °F.
Color film 10 °C = 50 °F.

Lower temperatures would not entail any inconvenience. The desired temperature will be reached faster under cold climatic conditions.

Bringing the film to shooting temperature

Before opening the cans bring the film to « location temperature ». The following table indicates in hours the time necessary to compensate the temperature differences.

Temperature difference	15° Centig. 59 °F		30° Centig. 86 °F	
	70 %	90 %	70 %	90 %
Insulated 16 mm can	1/2	1 h	1 h	2 h
Insulated 35 mm can	1 1/2 h	3 h	3 h	6 h
Cardboard 16 mm & 35 mm	18 h	36 h	36 h	72 h

Cold. If a film has a too high temperature under cold climatic conditions, it dries up rapidly and becomes brittle. Cracks can occur near the loops and the sprocket-wheels.

Heat. If a film has a too low temperature, in hot climates, it is susceptible of condensation on the surface; as a result the emulsion becomes soft and sticky that leaves in the camera gate emulsion deposits which result in scratches and film jammings.

Exposure

The sensitivity of cinematographic films is conserved to — 20 °C (4 °F) and one would have to reach a temperature of — 55 °C (— 67 °F) for obtaining a loss of the diaphragms sensitivity.

In summary :

- Keep the film at indicated temperature.
- Avoid unnecessary temperature variations.
- Make sure that film-cans have shooting temperature.
- Do not leave the film in the camera more than necessary.
- Develop the film as soon as possible.

HOT CLIMATES

Tropical and equatorial climates

The characteristics of these climates are high relative humidity passing 70 % associated with temperature of 30 °C (86 °F). We recommend to transport cameras and films in carrying-cases containing desiccating agents (moisture-absorbing product). If the carrying-cases are not sufficiently water-vaporproof use air-tight plastic-bags.

ECLAIR put these desiccatives in the carrying-cases; keep them as they can be reused indefinitely. Just expose them at a temperature of 120 °C (248 °F). The humidity which saturates the atmosphere is condensed when the temperature falls slightly; before sun-down put the material into the transport case and never leave the film in the camera over night.

Desert climates

The characteristics are very high temperatures during the day and chilly nights. As a result it is essential to use isothermic containers to protect the film from these temperature variations. These chilly nights will allow to store the film at an acceptable temperature.

The air-tight plastic bags are protecting the camera from dust, sand and laterite.

Utilisation

Keep the material in the shade of an airy place, avoid direct sun-light and storage in cars ETC...

- Bring the film to ambient temperature.
- Camera should not be loaded until immediately before use.
- After the end of shooting, place the exposed film and the short-ends in the original containers. Use dry black paper only.
- If the relative humidity rate is lower than 70 % seal the film cans by sticking adhesive tape on the periphery.
- If the relative humidity rate is higher than 70 %, stick the tape diagonally around the can and put the exposed film in an hermetically sealed container provided with a desiccative agent (avoid refrigerators).
- Develop the films as soon as possible.

The above mentioned precautions are valid for a period of approximately one month. Would you kindly consult us for longer periods which will of course necessitate other precautions.



COLD CLIMATES

Preparation

Check whether the camera has always been maintained and repaired by one of our agents; the use of appropriate lubricants, the respect of mounting tolerances for all moving parts etc... all this will give you the best guarantee for satisfactory service under frigid conditions.

For temperature lower than -15°C ($+5^{\circ}\text{F}$) would you please consult one of our agents. He will carry out a « Winterizing treatment » which has been elaborated by our research department.

Also check the lubrication of the adjusting rings of your lenses.

Temperature variations

Although the camera bears easily considerable and brutal slumps of temperature, a fast rise of temperature would be on the other hand, hazardous for the mechanism owing to the associated condensation.

The warming-up should take place slowly and not in warm air. Therefore, put the material in sealed transport cases or better in air-tight plastic bags.

Utilisation

Brings the film at outside temperature before opening the cans (see table « Film and Temperature »). Don't load the magazine until immediately before use.

After the end of shooting, unload the film and the short ends at the ambient temperature, then put them back in the original containers. Films cans should be sealed by sticking adhesive tape on the periphery.

Send the film as soon as possible to a laboratory. Make sure that the film was warmed-up before opening and before immersing it into the developing bath. If not, bring film and short-ends to the desired storage temperature.

Pack the material always at outside temperature in the transport case or in air-tight plastic bags.

It is now possible to bring the film to a heated location. But wait about two hours for compensating a temperature difference of 20°C (68°F) before opening the carrying cases or bags.

Batteries

The driving torque of the camera increases in the cold, the consumption can double so that the batteries must be fully charged. Keep the maintenance charge until the last moment (position E).

The contact between skin and cold metal is painful and could even be dangerous (loss of skin).

We recommend to cover with cloth tape all parts of the camera which could be in contact with skin and to wear silk gloves for all essential operations.

Snow

When shooting during snowfall, all corners and nooks will be filled with snow. Before entering with the camera in a heated location, brush off very carefully the snow; then put it in an air-tight bag, in order to avoid unnecessary humidity in the transport case. Once warmed up, lay out separately all parts of the camera, clean them with care, dry them (i.e. with a hair dryer) and make a running test.

These above-mentioned precautions concern a short storage period only (approximately one month). Would you kindly consult us for longer periods.



USEFUL INFORMATION

Weights and sizes :

Camera front head .	1,175 kg	160x85x115 mm
Mivar motor	0,845 kg	176x72x45 mm
	with intermediate plates and screws	
Angenieux viewfinder	0,610 kg	100x87x125 mm
Lens protector	0,030 kg	∅ 68 mm
Handgrip	0,270 kg	158x47x35 mm
60 m (200 ft) magazine	1,735 kg	242x165x67 mm
120 m (400 ft) magazine	2,900 kg	289x202x78 mm
Mible feed cable	0,235 kg	1-2 mètres
Pilotone module	0,245 kg	102x67x33 mm

Zoom 6x9,5 (9,5/57 mm)	0,890 kg	165x67 mm
Zoom 10x12 (12/120 mm)	0,945 kg	180x120 mm
Zoom 6x12,5 (12,5/75 mm)	0,530 kg	140x59 mm
Mibac battery	0,640 kg	150x95x29 mm
Mirap charger	2,190 kg	200x100x95 mm
Bakel battery	1,650 kg	230x160x40 mm
Cibre charger	0,420 kg	125x64x40 mm
Bakel belt battery	2,750 kg	—
Carrying case	6,300 kg	0,70x0,50x0,19 mm

ACL TIME EXPOSURE

$$\text{Formula : } T = \frac{C \times S}{O}$$

$$\text{Example : } \frac{1}{49\text{th}} = \frac{360 \times 24}{175}$$

T = time of exposure

C = circonference

S = speed of filming (images per second)

O = opening of the shutter

i.e.	8 frames per second	=	1/16th
	12	»	= 1/24
	24	»	= 1/49
	25	»	= 1/51
	50	»	= 1/102
	75	»	= 1/154

Ref. NUMBERS AND FIGURES

Ners	DESIGNATION	PAGES	Ners	DESIGNATION	PAGES
1	Lens mount support.....	4-8	42	Motor drive spigots.....	30
2	Gelatine holder.....	4-9-19	43	Motor driver.....	30
3	Reflex viewfinder.....	4-9-18	44	Cannon plug (motor power supply).....	30
6	Multiduty mivar motor.....	4-5	45	Cannon socket (motor power supply).....	30
7	Motor electronics.....	4-5	46	Screw of the hand control knob of the motor.....	30
8	Electronic base 150 E.....	4-11-24	47	Battery condition warning lamp.....	5-24-30
9	Mechanism plate.....	4	48	Battery polyurethane case.....	12
10	Film gate.....	4-10-23	49	4 pin socket on MIBAC battery.....	12
11	Fixed guide bar.....	4-10-23	50	Socapex central socket on battery.....	12-27
12	Spring loaded side pressure bar.....	4-10-23-29	51	Charger main supply socket.....	27
13	Claw.....	4-10	52	Charger safety fuse.....	27
14	Oscillating mirror.....	4-9-10	53	Magazine counter arm.....	21
15	Shutter.....	4-23	54	Magazine light tight ramp.....	21
16	Magazine lock release lever.....	4-23	55	Magazine flange.....	21
17	Safety catch.....	4-23	56	Magazine body.....	21
18	Magazine drive shaft.....	4-23	57	Counter arm lock.....	21
19	4 pin power supply socket.....	4-11	58	Magazine nose.....	21-22
20	Clapper switch.....	4-11-20-24	59	Magazine upper roller.....	21
21	Internal thread for C lenses.....	8-17	60	Magazine upper roller.....	21
22	External thread for intermediate lens mount.....	8	61	Magazine upper film guide.....	21
23	Intermediate mount location slot.....	8-17	62	Pressure pad.....	21-29
24	Intermediate mount location tongue.....	7-17	63	Magazine lower film guide.....	21
25	Intermediate mount grooved ring.....	7-17	64	Magazine upper roller shoe.....	21
26	CA mount slot.....	17	65	Upper and lower shoes catch.....	21
27	Gelatine holder button.....	9-19	66	Feed sprocket.....	21
28	Hole for eventual film marking system.....	10	67	Magazine lower roller shoe.....	21
29	Magazine guide.....	4-10	68	Magazine location tongues.....	21
30	Magazine guide.....	4-10	69	Loop separator.....	21
31	Motor knurled knob.....	5-24-30	70	Magazine flange (interchangeable with 55).....	22
32	On/off switch of the electronic base.....	4-11-20-24	71	Spool lock.....	22
33	Accessory power supply cannon socket.....	11	72	Footage counter dial (60 m magazine).....	21-22
34	Sensitivity potentiometer (exposure indicator).....	4-11-10	73	Footage counter pointer.....	21-22
35	Speed control button on MIVAR motor.....	5-24-30	74	Magazine drive shaft.....	21-23
36	Handgrip.....	7-19-11	75	Handgrip side support.....	4-7-19
37	MIBAC battery.....	5-12	76	On/off switch of the handgrip side support.....	4-19-24
38	24/25 frames per second switch.....	5-24-30	77	Handgrip side support fixing screws.....	19
39	Claw control cam.....	10	78	Spare gelatine holder.....	19
40	Motor retaining screws.....	30	79	Knurled ring of the handgrip support.....	19
41	Rubber driver.....	30	80	Hole of the handgrip support.....	19



Ref. NUMBERS AND FIGURES

Ners	DESIGNATION	PAGES	Ners	DESIGNATION	PAGES
81	Handgrip half-moon lock	19	EF	BAKEL battery	13
82	Side support plug	19	FG	CIBRE charger	13
83	Lid lock button (120 m magazine)	22	GH	Transport case	13
84	White disc on rotatable lock (120 m magazine)	22	HI	Transport case (inside)	13
01	Resolving prism of the exposure indicator	25	JK	Cables and plugs	14
02	Ground glass of the exposure indicator	25	KL	Synchronization connections	15
03	Photo resistive element of the exposure indicator	25	LM	d°	15
04	Ceramic base of the exposure indicator	25	MN	d°	15
	FIGURES :		NO	d°	15
A	Camera head : front view	4	PQ	Viewfinder	18
B	Camera head : rear view	4	QR	Handgrip support	19
D	MIVAR motor. Front view	5	RS	Handgrip	19
E	MIVAR motor. Rear view	5	ST	Handgrip side support with microswitch	19
F	60 m magazine, take-up side	6	TU	Exploded diagram of the electronic base 150 E	20
G	Mounting the magazine on the camera	6-23	UV	Diagram n° 45112	20
H	120 m magazine	6	VX	Diagram n° 45113	20
I	ACL with 120 m magazine on shoulder	6	XY	60 m (200 ft) magazine	21
J	Handgrip under the camera	7	YZ	d°	21
K	Handgrip on the side of the camera	7	ZZ	d°	22
L	Lens with C mount	7	AC	120 m (400 ft) magazine, feed side (closed)	22
L1to L9	External elements of the viewfinder	18	G	Mounting the magazine on the camera	6-23
M	Zoom lens with eclair CA mount	7	CE	On/off switch positions	24
N	Intermediate mount	7	DF	MIRAP charger	27
O	Camera head	8	EG	MIBAC battery (in charge)	27
P	Intermediate mounts for eclair CA, Arriflex, Nikon	8	FH	MIRAP charger (bottom view)	27
Q	Camera ground glass	9	GI	BAKEL battery	28
R	Gelatine holder	9	HJ	CIBRE charger	28
S	Exploded diagram of the mechanism	10	IK	MIVAR motor (front view)	30
T	Exposure indicator principle	25	JL	MIVAR motor (rear view)	30
U	Exposure indicator computer	25	KM	Camera head without motor (side view)	30
V	Location of the LED	25			
X	Part of the 150 E electronic base	11			
Y	Pilotone module, tape recorder side	11			
Z	Pilotone module, camera side	11			
AB	MIBAC Battery	12			
BC	MIRAP charger	12			
CD	Rapid charger diagram	12			
DE	Temperature compensation (diagram)	12			

SOREMEC-CEHESS

Département "ÉCLAIR INTERNATIONAL"

41-45, rue Galilée - 75116 PARIS

Tél. 723.78.56 +

Télex : 610 663 F ÉCLAIRE

Câble : ÉCLAIRCAM PARIS